



Park District of Oak Park

## Transition Plan Executive Summary

Prepared by:  
Accessibility Consultation and Training Services, Inc.

October 2023

## Table of Contents

Park District of Oak Park Accessibility Survey Executive Summary.....	3
Policies and Procedures Review for Park District of Oak Park .....	7
Priorities Explanation .....	11
Accommodations Language for Registration Forms, Brochures, Website.....	12
Park District of Oak Park Grievance Procedure Example.....	13
Other Power Driven Mobility Device Policy .....	14
Service Animal Policy .....	15
Appendices .....	16
Park District of Oak Park Inclusion Policy	
Overview of Title II	
Additional Federal Information	
Justice ADA State and Local Governments	
Justice ADA - Wheelchairs, Mobility Aids & Other Power Driven Mobility	
Justice ADA Requirements - Service Animals	
Justice ADA Requirements - Effective Communication	
Justice ADA Requirements - Accessible Pools Means of Entry and Exit ADA	
National Network Planning Guide for Temporary Events	
Justice ADA Accessibility of State and Local Government Websites	

## Park District of Oak Park Executive Summary

The Park District of Oak Park comes under Title II of the Americans with Disabilities Act (ADA) for State and Local Governments. The Park District of Oak Park has the responsibility to provide equal and integrated access to its services, facilities, programs and activities for its residents and visitors with disabilities. To provide access, the Park District of Oak Park must make reasonable modifications to policies and procedures as well as physical changes to the built environment.

In addition to the physical assessment, the development of policies and procedures for Service Animals, Other Power Driven Mobility Devices (OPDMD), and Effective Communication recommendations and examples have been provided. Additional details and information on the Park District of Oak Park obligation under Title II can be found in the Appendices of this report. For the other policies and procedures noted see additional information on Service Animals, OPDMD, and Effective Communication in the Appendices as well.

The following comments are a summary of the Park District of Oak Park accessibility evaluation and Transition Plan development for 25 parks and facilities. Each public facility used for programs was reviewed for their compliance with the 2010 Americans with Disabilities Act Accessibility Guidelines (ADAAG), the Illinois Accessibility Code (IAC) that includes the Outdoor Developed Area Guidelines. In addition, all elements were evaluated using Equivalent Facilitation standards (ADAAG 103) and Dimensional Tolerances (ADAAG 104.1.1).

In addition, a review of the District's policies and procedures was conducted. Included in this summary is an Inclusion Policy and Procedure draft for increasing participation of people with disabilities in your programs. Comments for this review and the accessibility issues noted are by using the standards developed for the Americans with Disabilities Act (ADA), findings from the Department of Justice and review of previous clients policy and procedures. The Transition Plan and policy and procedure review are working documents that should be continually reviewed and updated as changes are made.

Under Title II of the ADA, the regulations prohibit public entities such as the Park District of Oak Park from discriminating against or excluding a person from programs, services or activities on the basis of disability. Park District of Oak Park is responsible to meet the obligations of Title II of the ADA and assign a person as the ADA Coordinator. The ADA Coordinator is responsible to receive, review, and respond to questions and concerns expressed by a person with a disability related to access of the parks and programs. In addition, this person would be responsible to implement removal of access barriers recognized in the Transition Plan.

It should be noted that in existing facilities you are permitted to reassign a program from an inaccessible location to an accessible location (28 C.F.R. §35.150(a)(1);(b)(1)). Any facility built during the time the ADA was enforced is obligated to follow new construction standards and should be accessible. Also the ADA requires that at a minimum one

accessible route be provided (ADAAG 206.2). However, each park, building, and facility has been reviewed for their accessibility including multiple entrances, features, elements, facilities etc. This is so that as the various areas are updated and changes are made, the access issues that exist can be corrected at that time.

**Priority Parks and Facilities for Barrier Removal**

The Park District of Oak Park maintains 25 parks and facilities. A variety of activities are available for residents and guests. Activities and facilities can vary from recreation centers, meeting centers, special events, pool, fitness center, etc. There are activities for a variety of ages and interests.

An overall review of the parks and facilities indicates various accessible route issues such as slopes, abrupt transitions, gaps, surfaces, plus not providing them to various elements such as trash cans, player benches, picnic tables and park benches. Parking spaces at several locations have issues related to slopes, striping, location and lack of signage. In addition, accessible routes are not provided, have surface and slope issues. These elements are considered by the ADA as the highest priority for removal of barriers and should be completed as soon as possible. Other issues relate to protruding branches that could injury a person who is blind or has low vision, and signage in many locations are mounted on the door and not on the latch side.

Most restrooms have various accessibility violations such as toilet centerlines, stall doors not self closing or providing handles and coat hooks in the stall mounted too high. These barriers make the restrooms not totally up to code but still very usable. It should be noted that the portable toilets did not have proper spacing and design.

The parks listed below are recommended to have a higher priority for removal of accessibility barriers. These parks and facilities are recommended because of their unique features, facilities, programs and locations throughout the village. The intent of these recommendations is to assist the Park District in removing accessibility barriers that would have the highest impact for the most number of people. They include:

<b>Carroll Center/Park</b>	<b>Community Recreation Center</b>	<b>Elizabeth F. Cheney Mansion</b>
<b>Oak Park Conservatory</b>	<b>Dole Center</b>	<b>Fox Center/Park</b>
<b>Lindberg Park</b>	<b>Mills Park/Pleasant Home</b>	<b>Gymnastics and Recreation Center</b>
<b>Rehm Pool and Park</b>	<b>Ridgeland Common Recreation Complex and Paul Hruby Ice Arena</b>	<b>Taylor Park</b>

## Planning Categories for Accessibility Barrier Removal

The following three categories are intended as a helpful tool for the removal of accessibility barriers. The categories include ongoing maintenance, Transition Plan implementation and capital projects. The issues and elements noted under each category are not intended as a definitive list but are a means to assist in the planning for and removal of accessibility barriers in a cohesive and cost effective manner. All items and elements are subject to a shorter replacement schedule if a request or complaint is made by a person with a disability to increase access to programs, services and activities that are offered.

### **Annual Maintenance or Review of Accessibility Issues**

The following list is intended as items that are accessibility issues that are likely to occur each year. These accessibility issues could be removed and adjusted only once a year. In some cases, (such as playground surfaces, door force and timing, debris, etc.) consideration should be made to provide adjustments or removal more than once a year.

- Accessible route - removing debris or elements that have been placed in the accessible route and checking general surface conditions for replacement or re-coating including walkways, parking lots, curb ramps, gutters, etc.
- Branches protruding into walkways and sidewalks.
- Clear floor space and accessible routes – Make sure loose furniture or other loose items (trash cans, ash cans, etc.) do not interfere with accessible routes and clear floor spaces at sinks, toilets, door maneuvering spaces, bench and bleacher clear floor space.
- Door opening force or timing for closing (both exterior and interior doors).
- Exercise equipment's clear floor space.
- Parking spaces needing repainting especially the access aisles.
- Reach range of elements that may have been moved or remounted (brochure racks, soap dispensers, paper towel dispensers, comment boxes, dog disposal bags, etc.).
- Operable parts and replacements if broken (i.e. door and faucet hardware, switches, push buttons, door bells, play equipment handles, etc.)
- Playground engineered wood fiber maintenance.

### **Removal of Accessibility Barriers or Required Upgrades**

The following list of elements could be items that are accessibility barriers noted in the Transition Plan. These are items that do not typically fall into annual maintenance or are a costly item that requires extensive planning or financial support to make the changes.

- Accessible routes that require modifications or replacement such as broken or uneven surfaces, filling gaps, grinding down abrupt transition, modifying slopes, etc.
- Assistive listening devices at assembly or meeting areas/rooms.
- Benches – In locker rooms, dressing rooms, outdoor benches, etc.
- Clear floor space at benches, bleachers, drinking fountains, sinks, telephones, etc.
- Clear swing hinges for widening door clear openings.
- Counter heights.
- Curb ramps and gutters.

- Detectable warnings.
- Door hardware replacement – lever hardware, loop hardware, etc.
- Door and shower thresholds.
- Drinking fountain adjustment or replacement.
- Edge protection at ramps.
- Grab bars – height adjustment, locations, replace with proper sized grab bars, etc.
- Handrails – installation, extensions, replacement, gripping surface, spacing, etc.
- Lockers – lower or raise shelf, lower or raise coat hooks, accessible door hardware, etc.
- Parking spaces – sign locations and heights, parking slopes, proper size of spaces, built-up curb ramps in access aisles, etc.
- Picnic tables of accessible designs, locations, percentages, etc.
- Playground – access to surface, access to elevated elements (transfer platform and/or ramps), ground level play equipment numbers.
- Pool – Lifts, zero depth or sloped entries, transfer systems and/or pool stairs.
- Protruding objects or elements.
- Reach range adjustments for various elements.
- Shower – seat, and grab bars installed.
- Signage – installed or remounting.
- Sink – accessible design/faucets, mounting heights, protective pipe wrap or cover, mounting locations.
- Stairs – tread nosing adjustments, closing open risers, stair surface, etc.
- Toilet – heights, locations, lever location, etc.
- Toilet paper – heights and locations.
- Toilet stall door – locations, hardware, self-closing, etc.
- Urinal – heights, clear floor space, flush control reach ranges, etc.

### **Capital Planning or Renovation Projects**

In some cases projects may require extensive planning or significant capital to remove the accessibility issues. Some parts of elements or accessibility barriers in these areas maybe removed or adjusted to increase access until the time of the major renovation. Other issues may require moving of walls, plumbing, openings, etc. to provide the access.

- Bleacher replacements
- Automatic door openers
- Door clear maneuvering or clear openings
- Elevator
- Playground replacement – This can include requirements to access elevated play components reflected in the Transition Plan.
- Ramp upgrades/replacement/installation
- Shower – upgrades or redesign.
- Stair upgrades/replacement
- Toilet rooms/stalls reconfiguration for spacing

## Policies and Procedures Review for Park District of Oak Park

The review of policies and procedures is being conducted in accordance with the Americans with Disabilities Act (ADA). The ADA requires all public entities to review their policies and procedures to determine if any discriminate against a person with a disability participating in their programming. Integration and inclusion of people with disabilities within a program is a fundamental principle of the ADA (28 C.F.R. §35.130(a)).

A public entity's programs, services and activities cannot be offered if it is not equal to or not as effective as what is provided to others. In addition, no eligibility criteria for participation in a program can not be used to screen out people with disabilities either directly or indirectly unless the criteria is necessary for the program's activity. The intent is to provide equal access to all programs offered by the Park District of Oak Park (28 C.F.R. §35.130(b)(1)(i)-(iv),(vii)).

The Park District of Oak Park's programs, services and activities can make reasonable modifications to policies and procedures to avoid discrimination to a person with a disability. A modification is not required if it would fundamentally change the nature of the program or activity. In addition, it would not be required to be changed if it would cause a direct threat to that person or other participants. (28 C.F.R. §35.104, 28 C.F.R. §35.130(b)(7), 28 C.F.R. §35.150(a)(3)) and 28 C.F.R. §36.208).

No surcharges can be charged by the public entity to cover the cost of effective communication, program modifications or access features and they may not impose any additional requirements or burdens on people with disabilities that they do not require of all participants in the program (28 C.F.R. §35.130(f)).

All programs must be offered in as integrated a setting as possible. Separate programs and activities are permitted only when this design ensures equal opportunity for a person with a disability. When a separate program is offered, qualified individuals with a disability cannot be excluded from participating in regular programs if they choose to do so (28 C.F.R. §35.130(b)(2);(d)).

When the public entity contracts with another organization to provide programs and services to the entity's constituents, the public entity must ensure that, the contractor provides services and activities in a nondiscriminatory manner that are consistent with the requirements of Title II of the ADA (28 C.F.R. §35.151(Preamble)).

In relationship to contractors, the public entity cannot discriminate against a company that employs a person with a disability. The acceptance or non-acceptance of a company must be determined by their qualifications only (28 C.F.R. §35.130(b)(5)).

The Park District of Oak Park must designate a person as the ADA Coordinator. This person is responsible to continue the barrier removal process by determining an approximate date for removal and recording when changes have been made. In addition, they are available to answer questions or concerns by the public related to accessibility issues. Their contact information should be provided on the website and printed materials such as you brochure.

## Website Accessibility

Although the actual recommended guidelines for website accessibility are not yet law, the Justice Project Civic Access is citing web accessibility in its settlement agreements. Using these agreements as a guide, we would recommend the following for web accessibility.

1. Designate an employee as the web accessibility coordinator who will be responsible for coordinating website compliance. The web accessibility coordinator should have experience with the requirements of Title II of the ADA, the Web Content Accessibility Guidelines (WCAG) version 2.0, and website accessibility generally. The unique environment of the world wide web mandates specific skill, language and protocols, so it is recommended to have a trained ADA Coordinator for this purpose.
2. Adopt, implement, and post online a policy that its web pages will comply with WCAG 2.0 AA, published by the World Wide Web Consortium (W3C), Web Accessibility Initiative (WAI), available at [www.w3.org/TR/WCAG](http://www.w3.org/TR/WCAG).
3. Distribute the policy to all employees and contractors who design, develop, maintain, or otherwise have responsibility for its websites, or provide website content, technical support, or customer service.
4. Provide training to website content personnel on how to conform all web content and services with, at minimum, WCAG 2.0 AA.
5. Assess all existing web content and online services for conformance with, at minimum, WCAG 2.0 AA, by:
  - a. performing automated accessibility tests of its website and all online services, using an automated tool approved by the United States, to identify any accessibility barriers.
  - b. enlisting individuals with different disabilities, including at a minimum individuals who are blind, deaf, and have physical disabilities (such as those limiting the ability to use a mouse), to test its pages for ease of use and accessibility barriers.
6. Provide a notice, prominently and directly linked from the homepage, instructing visitors to its websites on how to request accessible information. The link should provide several methods to request accessible information, including an accessible form to submit feedback, an email address, and a phone number (with TTY) to contact personnel knowledgeable about the accessibility of the website.
7. Provide a notice, prominently and directly linked from the homepage, soliciting feedback from visitors to its websites on how to improve website accessibility. The link should provide several methods to provide feedback, including an accessible form to submit feedback, an email address, and a phone number (with TTY) to contact personnel knowledgeable about the accessibility of the website.
8. Your entity may rely on third parties for some of their website infrastructure such as scheduling. You must ensure that your websites and all online services, including those websites or on-line services provided by third parties upon which members of the public participate in or benefit from services, programs, or activities, comply with, at minimum, WCAG 2.0 AA.



## Communication

- Provide materials in alternate formats. If the materials such as a registration form is not provided on the website, provide large print versions for a person with limited sight to fill out.
- Provide qualified sign language interpreters at all public meetings. Gather a list of sign language interpreters for programs as needed.
- Assistive listening devices should be available for any public meetings or programs. A portable unit would be usable in various locations and situations.
- Provide Braille versions of information.
- Provide general information of programs on a disk for a person to access at home.
- Purchase a TTY system at your main phone. Include the TTY number in all your publications.
- Provide pad of paper at all public locations if communication by writing is the only means at the moment.

## Brochure and Registration

- Provide in all brochures your efforts to comply with the Americans with Disabilities Act (ADA). Include information to encourage their comments and suggestions.
- Provide contact information for the person responsible as the ADA Coordinator for the Park District of Oak Park.
- For the dog policy, see separate information on service animals.

## Parks and Facilities

- Locate all loose items away from all clear floor spaces. Provide trash cans, picnic tables, benches, etc. along accessible routes. Some items may also need additional access features such as a concrete pad underneath them or to a side.
- Train janitorial staff to place all loose items in restrooms such as garbage cans away from the clear floor space requirements of sinks, hand dryers, paper towel dispensers, soap dispensers, etc.
- Provide a regular schedule to trim all trees and bushes from protruding into an accessible route.
- A minimum of once a week regrading of engineered wood fiber in playgrounds and other locations to keep the surface accessible.
- Provide a service dog policy to allow qualified dogs to attend programs with their owners. See separate information on service animals. Evaluate all locations and programs to determine if a service animal may not be appropriate.
- Have all construction contracts noted to meet all code requirements of the Americans with Disabilities Act Accessibility Guidelines (ADAAG).
- Note in all construction documents that the cross slope not exceed 2%.
- When ordering portable accessible toilets, make sure the supplier has accessible toilets that meet all the new ADA Accessibility Guidelines (ADAAG) requirements.
- Make sure the portable toilet supplier delivers them to an accessible site including surface and accessible route.

### Staff Training and Development

- Provide in all staff manuals information on appropriate and inappropriate language to use for a person with a disability.
- Discontinue in all manuals, handouts and website the use of the word “handicapped”. Use person first language, i.e. a person with a physical disability, Jill with a hearing impairment, etc.
- Provide disability awareness trainings for staff.

### Transportation

- If the public entity, such as a park district, provides transportation, then an accessible vehicle must be available if a request is made.
- If renting transportation, determine that the company has available accessible vehicles if necessary when requested by a participant.
- Option: Providing a policy to rent only accessible vehicles ensure that accessibility is provided.

## Priorities Explanation

The following is an overview of the elements that may need to be modified for accessibility and the recommended order noted in the preamble of the Americans with Disabilities Act.

**Priority 1** (Highest Priority) From parking up to and through a door of a building or up to specific area (Such as a picnic shelter, playground, building entrance, etc.)

- Removal of barriers to elements such as or related to a parking, sidewalks, drop-off areas, accessible routes, curb ramps, surfaces, ramps, stairs, protruding objects, doors, entrances, etc.

**Priority 2** (From entrance of a building to different elements within the structure or within a specific area (such as a building's rooms, playground, garden, golf course, etc.).

- Removal of barriers to elements such as or related to accessible routes, protruding objects, ground and floor surfaces, ramps, stairs, lifts, elevators, signage, doors and entrances.

**Priority 3** (Within a restroom and shower area)

- Removal of barriers such as or related to accessible routes, water closet, toilet stalls, urinals, lavatories, shower stalls, toilet rooms, handrails, sinks and signage.

**Priority 4** (Lowest Priority) (Elements not critical to participating in a program but noted in the Americans with Disabilities Act Accessibility Guidelines (ADAAG))

- Removal of barriers to elements such as or related to mirrors, drinking fountains, telephones, etc.

## Accommodations Language for Registration Forms, Brochures, Website

### **ADA Statement Park District of Oak Park**

In accordance with the requirements of Title II of the Americans with Disabilities Act of 1990 (ADA), the Park District of Oak Park will not discriminate against qualified individuals with disabilities on the basis of disability in its services, programs or activities. If you feel that you or someone you know has been discriminated against or you have a recommendation on increasing accessibility of the Park District's services, programs and activities please contact the ADA Coordinator at (630) 231-9474; TTY 7-1-1 to discuss this items further. Concerns can also be emailed to: ADAcoordinator@pdop.org

### **Reasonable Accommodation Statement**

The Park District of Oak Park is committed to accessibility to all individuals with disabilities and strives to comply with the 1990 Americans with Disabilities Act (ADA) through equal and integrated participation. Please advise Park District of Oak Park of any special assistance, accommodations, auxiliary aids or services we can provide for you to participate in our programs, activities, services, meeting, etc. Please indicate your reasonable accommodation needs in the space provided below or contact the ADA Coordinator at (630) 231-9474; TTY 7-1-1 or ADAcoordinator@pdop.org to discuss your accessibility needs. We ask your request be provided a minimum of 72 hours before the scheduled event or meeting. If a request is made less than 72 hours before the event the Park District of Oak Park will make a good faith effort to accommodate your request.

## Park District of Oak Park Grievance Procedure Example

### Grievance Procedure under The Americans with Disabilities Act (ADA)

This Grievance Procedure is established by the Park District of Oak Park to meet the requirements of the Americans with Disabilities Act of 1990 ("ADA"). It may be used by anyone who wishes to file a complaint alleging discrimination on the basis of disability in the provision of services, activities, programs, or benefits by the Park District of Oak Park. The Park District of Oak Park's Personnel Policy governs employment-related complaints of disability discrimination.

1. The complaint should be in writing and contain information about the alleged discrimination such as name, address, phone number of complainant and location, date, and description of the problem. Alternative means of filing complaints, such as personal interviews or a tape recording of the complaint, will be made available for persons with disabilities upon request.
2. The complaint should be submitted by the grievant and/or his/her designee as soon as possible but no later than 60 calendar days after the alleged violation to
3. 

---

Within 15 calendar days after receipt of the complaint, the ADA Coordinator or his/her designee will meet with the complainant to discuss the complaint and the possible resolutions. Within 15 calendar days of the meeting, the ADA Coordinator or his/her designee will respond in writing, and where appropriate, in a format accessible to the complainant, such as large print, Braille, or audiotape. The response will explain the position of the Park District of Oak Park and offer options for substantive resolution of the complaint.
4. If the response by the ADA Coordinator or his/her designee does not satisfactorily resolve the issue, the complainant and/or his/her designee may appeal the decision within 15 calendar days after receipt of the response to the Park District's Executive office or his/her designee.
5. Within 15 calendar days after receipt of the appeal, the Park District of Oak Park Manager's office or his/her designee will meet with the complainant to discuss the complaint and possible resolutions. Within 15 calendar days after the meeting, the Park District Executive's office or his designee will respond in writing, and, where appropriate, in a format accessible to the complainant, with a final resolution of the complaint.
6. All written complaints received by the ADA Coordinator or his/her designee, to the Park District of Oak Park's Executive office or his/her designee and the responses from those two offices will be retained by the Park District of Oak Park for at least three years.
7. The right of a person to prompt and equitable resolution of the complaint filed hereunder shall not be impaired by the person's pursuit of other remedies such as filing of an ADA complaint with the responsible federal department or agency. Use of this grievance procedure is not prerequisite to the pursuit of other remedies.

---

Park District Official

## Other Power-Driven Mobility Device Policy

### Use of Other Power Driven Mobility Devices (OPDMD) on Park District of Oak Park Property

The Park District of Oak Park is dedicated to providing all of its guests with equal access to its features and amenities. The Park District of Oak Park has taken into consideration the use of other power-driven mobility devices in accordance with 28 Code of Federal Regulations section 35.104 and factors such as impacts on other users, the safety of other users, impacts on property and infrastructure, and the noise level of such devices. The Park District has determined that it will permit the use of other power driven mobility devices ("OPDMDs"), as defined below, at parks, on hard surface trails, sidewalks and Park District facilities, and has developed this policy.

**Definition:** An other power driven mobility device (OPDMD) is a device used by a person with a mobility disability. This definition does **not** include gasoline powered devices or vehicles, golf carts, or riding lawn mowers. This definition is restricted to a device with the following is restricted to a device with the following specifications:

- a) Must not exceed more than one-half the width of any trail, path or sidewalk on which a device is being used; and
- b) For indoor use, must not exceed 36"; and
- c) Must not weigh more than 250 pounds; and
- d) Must be designed to travel on two or more low-pressure tires; and
- e) Must operate by electric powered engine with a maximum decibel level of 55 or less.

**Permission:** In order to maintain a safe pedestrian environment and the desired pace and flow of visitor traffic, the Park District of Oak Park authorizes persons with mobility impairments to use OPDMDs at parks, on hard surface trails and at Park District of Oak Park facilities, subject to the following restrictions:

1. The operator of the OPDMD must be a person with a mobility or physical impairment, and proof of such impairment may be requested by Park District of Oak Park personnel in accordance with ADA regulations;
2. The OPDMD is allowed only in areas of the park, hard surface trail or Park District of Oak Park facilities in which the general public is allowed.
3. The OPDMD operator must not use or operate such a device at a park, on a hard surface trail, or at Park District of Oak Park facilities if use of the device causes damage to the trail/path/sidewalk, the park grounds or infrastructure, or Park District facilities.
4. The OPDMD must be operated at a speed that is relative to surrounding foot traffic.
5. The OPDMD:
  - a. Must not be operated in a dangerous or reckless manner or at speeds that jeopardize the safety of the operator, or other persons.
  - b. Must not be driven into wet or ecologically sensitive or hazardous areas.
  - c. Must not be operated when parks or Park District of Oak Park facilities are not in operation.
6. The Park District of Oak Park does recognize the use of Segways® as an appropriate device for use inside Park District facilities unless for the following reasons:
  - a. The congestion of foot traffic within the facility may create a hazardous environment.
  - b. The manufacturer's recommendation for helmet and protective equipment for riders, much like bicycles, skateboards and rollerblades must be followed.
7. The Park District of Oak Park does not accept responsibility for storage of the OPDMD
8. The Park District of Oak Park does not accept responsibility or is held liable for damage to the OPDMD, or injury to the operator, whether caused by the operator, another visitor to a facility or site, or any other circumstance.
9. The Park District of Oak Park reserves the right to suspend the use of facilities or sites by the OPDMD operator if doing so is in the best interests of the Park District of Oak Park and its participants.
10. The Park District of Oak Park reserves the right to change, modify, or amend this policy at any time, as it deems appropriate.

## Service Animal Policy

### Use of Service Animals at Park District of Oak Park Parks and Facilities

The Park District of Oak Park has provided a detailed and well thought out policy and procedure for service animals. The following are a few more details that maybe helpful to include in their policy and procedures especially for miniature horses.

**Definition: Service animals are defined as dogs that are individually trained to do work or perform tasks for people with disabilities.** Examples of such work or tasks include guiding people who are blind, alerting people who are deaf, pulling a wheelchair, alerting and protecting a person who is having a seizure, reminding a person with mental illness to take prescribed medications, calming a person with Post Traumatic Stress Disorder (PTSD) during an anxiety attack, or performing other duties. Service animals are working animals, not pets. The work or task a dog has been trained to provide must be directly related to the person's disability. Dogs whose sole function is to provide comfort or emotional support do not qualify as service animals under the ADA.

**Please Note:** Miniature horse, with a general range in height of 24" to 34" and a weight between 70 lbs. and 100 lbs. are an alternate service animal to dogs. The horses are permitted if 1) the horse is house broken, 2) the horse is under control of the owner, 3) the facility can accommodate the horse's type, size and weight, 4) and their presence does not compromise legitimate safety requirements for safe operations of the facility.

#### **Permission:**

A service animal is permitted in most public areas of Park District of Oak Park parks and facilities property UNLESS one of two exceptions is met: (1) The animal is out of control and the animal's handler does not take effective action to control it; or (2) The animal is not house-broken.

A service animal shall have a harness, leash, or other tether, unless either the handler is unable because of a disability to use a harness, leash or other tether, or the use of a harness, leash or tether would interfere with the service animal's safe, effective performance of work tasks, in which case the service animal must be otherwise under the handler's control (e.g. voice controls, signals or other effective means).

Service animals are permitted in locker rooms, but not indoor shower facilities. (For assistance in shower facilities, please alert the Park District of Oak Park staff.)

Service animals must be in their official roles and under control at all times.

The Park District of Oak Park reserves the right to change, modify or amend this policy at any time as it deems appropriate.

## Park District of Oak Park Inclusion Policy

The Park District of Oak Park and West Suburban Special Recreation Association are committed to providing inclusive opportunities to participate in all programs, activities and services offered. We strive to provide these opportunities through reasonable accommodations such as inclusive aides, adapted equipment, sign language interpreters, accessible parks and facilities, modification to the program or activity, etc. The goal will be to provide the opportunity to participate in the recreation activities in the least restrictive environment possible. **Please Note:** All participants are expected to follow general behavior rules established for all participants in or programs. If behavior is considered a safety issue for that individual or other participants, it may result in their termination from the program.

It is important for us to know you or child as best as possible. In the registration form there will be a line to advise us of your need for an accommodation to participate in the program or activity you have noted. Within 10 days after receiving your registration form and information, an Inclusion staff member will contact you and discuss your needs over the phone or set up a meeting. Our goal is to better understand you or your child's needs and create a plan to better insure a positive experience.

Some of the information the staff person will need includes:

### General Information

- General information on the participant.
- Dietary restrictions
- Medications
- Functioning level

### Special Interests or Social Connections

- Areas of interest: Such as favorite books, games, television shows, etc.
- Hobbies: What does he/she like to do at home in their free time?
- Friendships/Siblings: People who will be in the program that they know

### Development

- Physical: Understand if any physical limitations to participate
- Emotional: Situations that upset or frighten the participant.
- Social: Any limitation to speech or has other means of communication. Do they use pictures or gestures to communicate?
- Understanding their comfort in social settings and interacting with others.
- Discuss the accessibility at the site and potential issues for the participant.

### Special Considerations or Situations

- Advise staff if a care attendant would be required
- If the participants has a service animal
- If the participant uses and Other Power Driven Mobility Device (OPDMD) other than a standard wheelchair or scooter.
- Special equipment they require
- Need for a sign language interpreter
- Behavioral management program



The Park District of Oak Park staff and West Suburban Special Recreation Association staff will communicate with parents or guardians about their child or friends progress after the program or activity. If a multiple week program the Inclusion Staff will contact you weekly about their child's progress and any additional questions they have to help ensure success.

**Personal and Invasive Service Policies**

Please be advised, the Park District of Oak Park staff and the West Suburban Special Recreation Association staff do not provide services of a personal nature such as changing cloths, injections, cauterization, g-tube feeding, etc. However we will allow the person who requires these services to bring a personal care attendant at no additional charge to enable them to participate.

## Park District of Oak Park - PARENT/GUARDIAN AGREEMENT

Participant Name: \_\_\_\_\_

Program Participating in: \_\_\_\_\_

- I understand that this service is not designed for therapeutic or one-on-one care.
- I understand that the Inclusion Aide does not dictate the structure of the program, and should I have concerns about the structure of the program, I should contact the Executive Director.
- I understand it is my responsibility to provide the West Chicago program staff with the most current information on my child/dependent and his/her abilities to assist in making modifications to meet his/her needs.
- I understand it is my responsibility to let the West Chicago program staff know if there are any changes to the information I have provided on my child/dependent as soon as a change occurs.
- I understand it is my responsibility to inform the West Chicago program staff for each program my child/dependent signs up for in which I wish to have his/her modifications in place.
- I understand that my child's/dependent's inclusion plan does not exempt him/her from following the Park District of Oak Park program rules and consequences. The modifications in place may assist him/her in meeting these rules, but does not exempt him/her from following them.
- I understand that if my child/dependent is unable to comply with these rules, even with use of the modifications in place, he/she will be subject to the Park District of Oak Park disciplinary procedures. Conferences, probationary periods and suspensions are some of the steps that may be taken to ensure participants and families are aware their placement in the program is in jeopardy. In some cases, participants may be subject to emergency suspension or expulsion if their behaviors are beyond our ability to control.

---

Parent/Guardian Signature

Date

### I. Who is Covered by Title II of the ADA?

The Title II regulation covers "public entities."

"Public entities" include any State or local government and any of its departments, agencies, or other instrumentalities.

All activities, services, and programs of public entities are covered, including activities of State legislatures and courts, town meetings, police and fire departments, motor vehicle licensing, and employment. Unlike section 504 of the Rehabilitation Act of 1973, which only covers programs receiving Federal financial assistance, Title II extends to all the activities of State and local governments whether or not they receive Federal funds. Private entities that operate public accommodations, such as hotels, restaurants, theaters, retail stores, dry cleaners, doctors' offices, amusement parks, and bowling alleys, are not covered by Title II but are covered by Title III of the ADA and the Department's regulation implementing Title III.

Public transportation services operated by State and local governments are covered by regulations of the Department of Transportation (DOT)). DOT's regulations establish specific requirements for transportation vehicles and facilities, including a requirement that all new busses must be equipped to provide services to people who use wheelchairs.

### II. Overview of Requirements

State and local governments

- May not refuse to allow a person with a disability to participate in a service, program, or activity simply because the person has a disability. For example, the Park District of Oak Park may not refuse to allow a person with epilepsy to use parks and recreational facilities.
- Must provide programs and services in an integrated setting, unless separate or different measures are necessary to ensure equal opportunity.
- Must eliminate unnecessary eligibility standards or rules that deny individuals with disabilities an equal opportunity to enjoy their services, programs or activities unless "necessary" for the provisions of the service, program or activity. Requirements that tend to screen out individuals with disabilities, such as requiring a driver's license as the only acceptable means of identification, are also prohibited.

Safety requirements that are necessary for the safe operation of the program in question, such as requirements for eligibility for drivers' licenses, may be imposed if they are based on actual risks and not on mere speculation, stereotypes, or generalizations about individuals with disabilities.

- Are required to make reasonable modifications in policies, practices, and procedures that deny equal access to individuals with disabilities, unless a fundamental alteration in the program would result.

## Overview of Title II

For example, a Park District of Oak Park office building would be required to make an exception to a rule prohibiting animals in public areas in order to admit guide dogs and other service animals assisting individuals with disabilities.

- Must furnish auxiliary aids and services when necessary to ensure effective communication, unless an undue burden or fundamental alteration would result.
- May provide special benefits, beyond those required by the regulation, to individuals with disabilities.
- May not place special charges on individuals with disabilities to cover the costs of measures necessary to ensure nondiscriminatory treatment, such as making modifications required to provide program accessibility or providing qualified interpreters.
- Shall operate their programs so that, when viewed in their entirety, they are readily accessible to and usable by individuals with disabilities.

### III. "Qualified Individuals with Disabilities"

Title II of the Americans with Disabilities Act provides comprehensive civil rights protections for "qualified individuals with disabilities."

An "individual with a disability" is a person who:

- Has a physical or mental impairment that substantially limits a "major life activity",
- or, Has a record of such an impairment,
- or, Is regarded as having such an impairment.

Examples of physical or mental impairments include, but are not limited to, such contagious and noncontagious diseases and conditions as orthopedic, visual, speech, and hearing impairments; cerebral palsy, epilepsy, muscular dystrophy, multiple sclerosis, cancer, heart disease, diabetes, mental retardation, emotional illness, specific learning disabilities, HIV disease (whether symptomatic or asymptomatic), tuberculosis, drug addiction, and alcoholism. Homosexuality and bisexuality are not physical or mental impairments under the ADA.

"Major life activities" include functions such as caring for oneself, performing manual tasks, walking, seeing, hearing, speaking, breathing, learning and working. Individuals who currently engage in the illegal use of drugs are not protected by the ADA when an action is taken on the basis of their current illegal use of drugs.

"Qualified" Individual.

A "qualified" individual with a disability is one who meets the essential eligibility requirements for the program or activity offered by a public entity.

The "essential eligibility requirements" will depend on the type of service or activity involved.

For some activities, such as State licensing programs, the ability to meet specific skill and performance requirements may be "essential."

For other activities, such as where the public entity provides information to anyone who requests it, the "essential eligibility requirements" would be minimal.

### IV. Program Access

State and local governments

- Must ensure that individuals with disabilities are not excluded from services, programs, and activities because buildings are inaccessible.
- Need not remove physical barriers, such as stairs, in all existing buildings, as long as they make their programs accessible to individuals who are unable to use an inaccessible existing facility.
- Can provide the services, programs, and activities offered in the facility to individuals with disabilities through alternative methods, if physical barriers are not removed, such as:
  - Relocating a service to an accessible facility, e.g., moving a public information office from the third floor to the first floor of a building.
  - Providing an aide or personal assistant to enable an individual with a disability to obtain the service.
  - Providing benefits or services at an individual's home, or at an alternative accessible site.
- May not carry an individual with a disability as a method of providing program access, except in exceptional circumstances.
- Are not required to take any action that would result in a fundamental alteration in the nature of the service, program, or activity or in undue financial and administrative burdens. However, public entities must take any other action, if available, that would not result in a fundamental alteration or undue burdens, but would ensure that individuals with disabilities receive the benefits or services.

### V. Integrated Programs

Integration of individuals with disabilities into the mainstream of society is fundamental to the purposes of the Americans with Disabilities Act.

Public entities may not provide services or benefits to individuals with disabilities through programs that are separate or different, unless the separate programs are necessary to ensure that the benefits and services are equally effective.

Even when separate programs are permitted, an individual with a disability still has the right to choose to participate in the regular program.

For example, it would not be a violation for a Park District of Oak Park to offer recreational programs specially designed for children with mobility impairments, but it would be a violation if the Park District of Oak Park refused to allow children with disabilities to participate in its other recreational programs.

State and local governments may not require an individual with a disability to accept a special accommodation or benefit if the individual chooses not to accept it.

### **VI. Communications**

State and local governments must ensure effective communication with individuals with disabilities.

Where necessary to ensure that communications with individuals with hearing, vision, or speech impairments are as effective as communications with others, the public entity must provide appropriate auxiliary aids.

"Auxiliary aids" include such services or devices as qualified interpreters, assistive listening headsets, television captioning and decoders, telecommunications devices for deaf persons (TDD's), videotext displays, readers, taped texts, Brailled materials, and large print materials.

A public entity may not charge an individual with a disability for the use of an auxiliary aid.

Telephone emergency services, including 911 services, must provide direct access to individuals with speech or hearing impairments.

Public entities are not required to provide auxiliary aids that would result in a fundamental alteration in the nature of a service, program, or activity or in undue financial and administrative burdens. However, public entities must still furnish another auxiliary aid, if available, that does not result in a fundamental alteration or undue burdens.

### **VII. New Construction and Alterations**

Public entities must ensure that newly constructed buildings and facilities are free of architectural and communication barriers that restrict access or use by individuals with disabilities.

When a public entity undertakes alterations to an existing building, it must also ensure that the altered portions are accessible.

The ADA does not require retrofitting of existing buildings to eliminate barriers, but does establish a high standard of accessibility for new buildings.

Public entities may choose between two technical standards for accessible design: The Uniform Federal Accessibility Standard (UFAS), established under the Architectural Barriers Act, or the Americans with Disability Act Accessibility

Guidelines, adopted by the Department of Justice for places of public accommodation and commercial facilities covered by Title III of the ADA.

The elevator exemption for small buildings under ADA Accessibility Guidelines would not apply to public entities covered by Title II.

### **VIII. Enforcement**

Private parties may bring lawsuits to enforce their rights under Title II of the ADA. The remedies available are the same as those provided under section 504 of the Rehabilitation Act of 1973. A reasonable attorney's fee may be awarded to the prevailing party.

Individuals may also file complaints with appropriate administrative agencies. The regulation designates eight Federal agencies to handle complaints filed under Title II.

Complaints may also be filed with any Federal agency that provides financial assistance to the program in question, or with the Department of Justice, which will refer the complaint to the appropriate agency.

### **IX. Complaints**

Any individual who believes that he or she is a victim of discrimination prohibited by the regulation may file a complaint. Complaints on behalf of classes of individuals are also permitted.

Complaints should be in writing, signed by the complainant or an authorized representative, and should contain the complainant's name and address and describe the public entity's alleged discriminatory action.

Complaints may be sent to --

Disability Rights Section  
Civil Rights Division  
U.S. Justice  
P.O. Box 66738  
Washington, D.C. 20035-6738

Complaints may also be sent to agencies designated to process complaints under the regulation, or to agencies that provide Federal financial assistance to the program in question.

### **X. Designated Agencies**

The following agencies are designated for enforcement of Title II for components of State and local governments that exercise responsibilities, regulate, or administer services, programs, or activities in the following functional areas:

**Agriculture:** Farming and the raising of livestock, including extension services.  
**Education:** Education systems and institutions (other than health-related schools), and libraries.

**Health and Human Services:** Schools of medicine, dentistry, nursing, and other health-related schools; health care and social service providers and institutions, including grass roots and community services organizations and programs; and preschool and daycare programs.

**Housing and Urban Development:** State and local public housing, and housing assistance and referral.

**Interior:** Lands and natural resources, including parks and recreation, water and waste management, environmental protection, energy, historic and cultural preservation, and museums.

**Justice:** Public safety, law enforcement, and the administration of justice, including courts and correctional institutions; commerce and industry, including banking and finance, consumer protection, and insurance; planning, development, and regulation (unless otherwise assigned); State and local government support services; and all other government functions not assigned to other designated agencies.

**Labor:** Labor and the work force.

**Transportation:** Transportation, including highways, public transportation, traffic management (non-law enforcement), automobile licensing and inspection, and driver licensing.

### **XI. Technical Assistance**

The ADA requires that the Federal agencies responsible for issuing ADA regulations provide "technical assistance."

Technical assistance is the dissemination of information (either directly by the Department or through grants and contracts) to assist the public, including individuals protected by the ADA and entities covered by the ADA, in understanding the new law.

Methods of providing information include, for example, audio-visual materials, pamphlets, manuals, electronic bulletin boards, checklists, and training.

The Department issued for public comment on December 5, 1990, a government-wide plan for the provision of technical assistance.

The Department's efforts focus on raising public awareness of the ADA by providing Factsheets and pamphlets in accessible formats,

Speakers for workshops, seminars, classes, and conferences,

An ADA telephone information line, and

Access to ADA documents through an electronic bulletin board for users of personal computers.

The Department has established a comprehensive program of technical assistance relating to public accommodations and State and local governments.



## Overview of Title II

Grants will be awarded for projects to inform individuals with disabilities and covered entities about their rights and responsibilities under the ADA and to facilitate voluntary compliance.

The Department will issue a technical assistance manual by January 26, 1992, for individuals or entities with rights or duties under the ADA.

For additional information, contact:

U.S. Justice  
950 Pennsylvania Avenue, NW  
Civil Rights Division  
Disability Rights Section, NYAV  
Washington, D.C 20035-6738

(800) 514-0301 (Voice)

(800) 514-0383 (TDD)

[www.ada.gov](http://www.ada.gov)



Americans with Disabilities Act

ADA Update:

A Primer for State and Local Governments

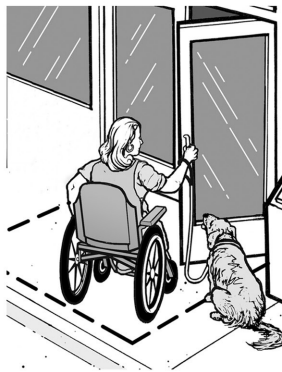
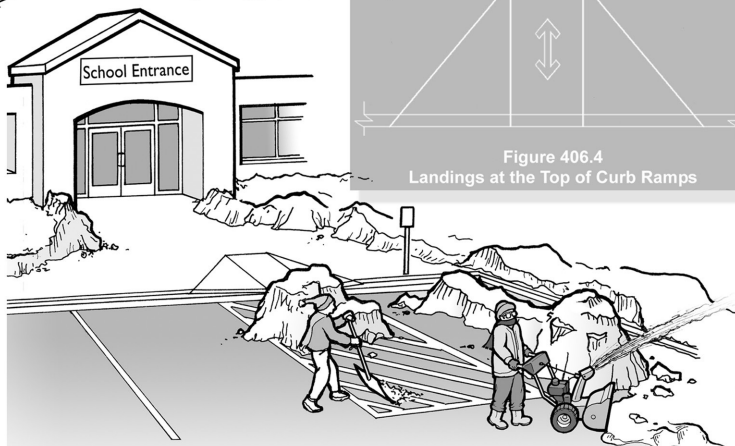
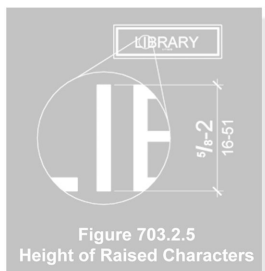
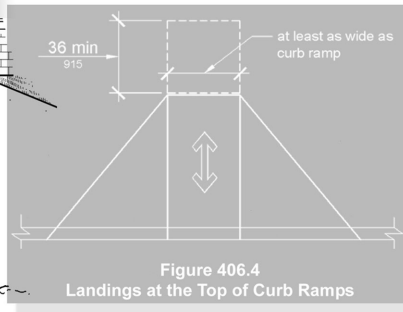
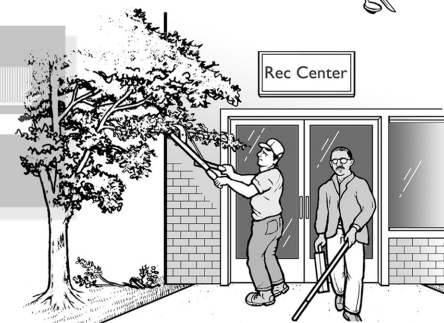
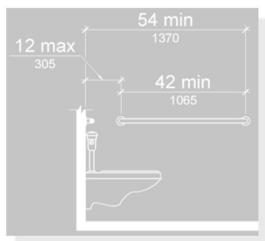
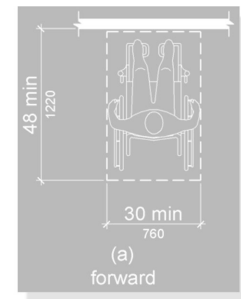
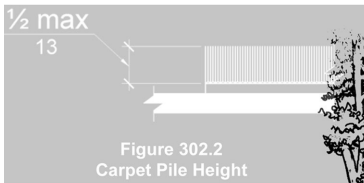

Figure 703.7.2.2 International Symbol of TTY



## TABLE OF CONTENTS

Introduction	1
Who Is Protected under the ADA?	1
Who Has Responsibilities under the ADA?	1
<b>GENERAL NONDISCRIMINATION REQUIREMENTS</b>	<b>2</b>
Basic Principles	2
Reasonable Modification of Policies and Procedures	3
Service Animals	4
Wheelchairs and Other Power-Driven Mobility Devices	6
Communicating with People Who Have Disabilities	7
<b>MAKING THE BUILT ENVIRONMENT ACCESSIBLE</b>	<b>9</b>
Access to Programs and Services in Existing Facilities	9
Element-by-Element Safe Harbor for Existing Facilities	11
Alterations	12
New Construction	12
Highlights of the 2010 Standards	13
<b>PLANNING FOR SUCCESS</b>	<b>14</b>
ADA Coordinator, Grievance Procedure, Self-Evaluations, and Transition Plans	15
Staff Training	15
<b>ADA INFORMATION RESOURCES</b>	<b>16</b>

## Introduction

More than 55 million Americans—18% of our population—have disabilities, and they, like all Americans, participate in a variety of programs, services, and activities provided by their State and local governments. This includes many people who became disabled while serving in the military. And, by the year 2030, approximately 71.5 million baby boomers will be over age 65 and will need services and surroundings that meet their age-related physical needs.

People with disabilities have too often been excluded from participating in basic civic activities like using the public transportation system, serving on a jury, voting, seeking refuge at an emergency shelter, or simply attending a high school sports event with family and friends. The Americans with Disabilities Act (ADA) is a Federal civil rights law that prohibits discrimination against people with disabilities. Under this law, people with disabilities are entitled to all of the rights, privileges, advantages, and opportunities that others have when participating in civic activities.

The Department of Justice revised its regulations implementing the ADA in September 2010. The new rules clarify issues that arose over the previous 20 years and contain new requirements, including the 2010 ADA Standards for Accessible Design (2010 Standards). This document provides general guidance to assist State and local governments in understanding and complying with the ADA's requirements. For more comprehensive information about specific requirements, government officials can consult the regulation ([www.ada.gov/regs2010/ADAregs2010.htm](http://www.ada.gov/regs2010/ADAregs2010.htm)), the 2010 Standards ([www.ada.gov/2010ADAstandards\\_index.htm](http://www.ada.gov/2010ADAstandards_index.htm)), and the Department's technical assistance publications ([www.ada.gov/ta-pubs-pg2.htm](http://www.ada.gov/ta-pubs-pg2.htm)).

### Who Is Protected under the ADA?

The ADA protects the rights of people who have a physical or mental impairment that substantially limits their ability to perform one or more major life activities, such as breathing, walking, reading, thinking, seeing, hearing, or working. It does not apply to people whose impairment is unsubstantial, such as someone who is slightly nearsighted or someone who is mildly allergic to pollen. However, it does apply to people whose disability is substantial but can be moderated or mitigated, such as someone with diabetes that can normally be controlled with medication or someone who uses leg braces to walk, as well as to people who are temporarily substantially limited in their ability to perform a major life activity. The ADA also applies to people who have a record of having a substantial impairment (e.g., a person with cancer that is in remission) or are regarded as having such an impairment (e.g., a person who has scars from a severe burn).

### Who Has Responsibilities under the ADA?

Title II of the ADA applies to all State and local governments and all departments, agencies, special purpose districts, and other instrumentalities of State or local government ("public entities"). It applies to all programs, services, or activities of public entities, from adoption services to zoning regulation. Title II entities that contract with other entities to provide public services (such as non-profit organizations that operate drug treatment programs or convenience stores that sell state lottery tickets) also have an obligation to ensure that their contractors do not discriminate against people with disabilities.

## GENERAL NONDISCRIMINATION REQUIREMENTS

---

### Basic Principles

Equal treatment is a fundamental purpose of the ADA. People with disabilities must not be treated in a different or inferior manner. For example:

- A city museum with an oriental carpet at the front entrance cannot make people who use wheelchairs use the back door out of concern for wear and tear on the carpet, if others are allowed to use the front entrance.
- A public health clinic cannot require an individual with a mental illness to come for check-ups after all other patients have been seen, based on an assumption that this patient's behavior will be disturbing to other patients.
- A county parks and recreation department cannot require people who are blind or have vision loss to be accompanied by a companion when hiking on a public trail.

The integration of people with disabilities into the mainstream of American life is a fundamental purpose of the ADA. Historically, public entities provided separate programs for people with disabilities and denied them the right to participate in the programs provided to everyone else. The ADA prohibits public entities from isolating, separating, or denying people with disabilities the opportunity to participate in the programs that are offered to others. Programs, activities, and services must be provided to people with disabilities in integrated settings. The ADA neither requires nor prohibits programs specifically for people with disabilities. But, when a public entity offers a special program as an alternative, individuals with disabilities have the right to choose whether to participate in the special program or in the regular program. For example:

- A county parks and recreation department may choose to provide a special swim program for people with arthritis. But it may not deny a person with arthritis the right to swim during pool hours for the general public.
- A state may be violating the ADA's integration mandate if it relies on segregated sheltered workshops to provide employment services for people with intellectual or developmental disabilities who could participate in integrated alternatives, like integrated supported employment with reasonable modifications; or if it relies on segregated adult care homes for residential services for people with mental illness who could live in integrated settings like scattered-site, permanent supportive housing.
- A city government may offer a program that allows people with disabilities to park for free at accessible metered parking spaces, but the ADA does not require cities to provide such programs.

People with disabilities have to meet the essential eligibility requirements, such as age, income, or educational background, needed to participate in a public program, service, or activity, just like everyone else. The ADA does not entitle them to waivers, exceptions, or preferential treatment. However, a public entity may not impose eligibility criteria that screen out or tend to screen out individuals with disabilities unless the criteria are necessary for the provision of the service, program, or activity being offered. For example:

- A citizen with a disability who is eighteen years of age or older, resides in the jurisdiction, and has registered to vote is "qualified" to vote in general elections.
- A school child with a disability whose family income is above the level allowed for an income-based free lunch program is "not qualified" for the program.

- If an educational background in architecture is a prerequisite to serve on a city board that reviews and approves building plans, a person with a disability who advocates for accessibility but lacks this background does not meet the qualifications to serve on this board.
- Requiring people to show a driver’s license as proof of identity in order to enter a secured government building would unfairly screen out people whose disability prevents them from getting a driver’s license. Staff must accept a state-issued non-driver ID as an alternative.
- The ADA allows (and may require – see below) different treatment of a person with a disability in situations where such treatment is necessary in order for a person with a disability to participate in a civic activity. For example, if an elected city council member has a disability that prevents her from attending council meetings in person, delivering papers to her home and allowing her to participate by telephone or videoconferencing would enable her to carry out her duties.
- There are some situations where it simply is not possible to integrate people with disabilities without fundamentally altering the nature of a program, service, or activity. For example, moving a beach volleyball program into a gymnasium, so a player who uses a wheelchair can participate on a flat surface without sand, would “fundamentally alter” the nature of the game. The ADA does not require changes of this nature.

Rules that are necessary for safe operation of a program, service, or activity are allowed, but they must be based on a current, objective assessment of the actual risk, not on assumptions, stereotypes, or generalizations about people who have disabilities. For example:

- A parks and recreation department may require all participants to pass a swim test in order to participate in an agency-sponsored white-water rafting expedition. This policy is legitimate because of the actual risk of harm to people who would not be able to swim to safety if the raft capsized.
- A rescue squad cannot refuse to transport a person based on the fact that he or she has HIV. This is not legitimate, because transporting a person with HIV does not pose a risk to first responders who use universal precautions.
- A Department of Motor Vehicles may require that all drivers over age 75 pass a road test to renew their driver’s license. It is not acceptable to apply this rule only to drivers with disabilities.

There are two exceptions to these general principles.

In some cases, “equal” (identical) treatment is not enough. As explained in the next sections, the ADA also requires public entities to make certain accommodations in order for people with disabilities to have a fair and equal opportunity to participate in civic programs and activities.

### **Reasonable Modification of Policies and Procedures**

Many routine policies, practices, and procedures are adopted by public entities without thinking about how they might affect people with disabilities. Sometimes a practice that seems neutral makes it difficult or impossible for a person with a disability to participate. In these cases, the ADA requires public entities to make “reasonable modifications” in their usual ways of doing things when necessary to accommodate people who have disabilities. For example:

- A person who uses crutches may have difficulty waiting in a long line to vote or register for college classes. The ADA does not require that the person be moved to the front of the line (although this would be permissible), but staff must provide a chair for him and note where he is in line, so he doesn't lose his place.
- A person who has an intellectual or cognitive disability may need assistance in completing an application for public benefits.
- A public agency that does not allow people to bring food into its facility may need to make an exception for a person who has diabetes and needs to eat frequently to control his glucose level.
- A city or county ordinance that prohibits animals in public places must be modified to allow people with disabilities who use service animals to access public places. (This topic is discussed more fully later.)
- A city or county ordinance that prohibits motorized devices on public sidewalks must be modified for people with disabilities who use motorized mobility devices that can be used safely on sidewalks. (This topic is discussed more fully later.)
- At a hot lunch program for elderly town residents, staff are not obliged to feed a woman with a disability who needs assistance in eating, if it does not provide this service for others. However, the woman should be allowed to bring an attendant to assist her. If she can feed herself but cannot cut large pieces of food into bite-sized pieces, it is reasonable to ask staff to cut up the food.
- If a city requires a 12-foot set-back from the curb in the central business district, it may be reasonable to grant a 3-foot variance for a store wishing to install a ramp at its entrance to meet its ADA obligations. If the set-back is smaller and the ramp would obstruct pedestrian traffic, granting the variance may "fundamentally alter" the purpose of the public sidewalk.

## Service Animals

Under the ADA, a service animal is defined as a dog that has been individually trained to do work or perform tasks for an individual with a disability. The task(s) performed by the dog must be directly related to the person's disability. For example, many people who are blind or have low vision use dogs to guide and assist them with orientation. Many individuals who are deaf use dogs to alert them to sounds. People with mobility disabilities often use dogs to pull their wheelchairs or retrieve items. People with epilepsy may use a dog to warn them of an imminent seizure, and individuals with psychiatric disabilities may use a dog to remind them to take medication. Dogs can also be trained to detect the onset of a seizure or panic attack and to help the person avoid the attack or be safe during the attack. Under the ADA, "comfort," "therapy," or "emotional support" animals do not meet the definition of a service animal because they have not been trained to do work or perform a specific task related to a person's disability.

Allowing service animals into a "no pet" facility is a common type of reasonable modification neces-

Only "reasonable" modifications are required. When only one staff person is on duty, it may or may not be possible to accommodate a person with a disability at that particular time. The staff person should assess whether he or she can provide the assistance that is needed without jeopardizing the safe operation of the public program or service. Any modification that would result in a "fundamental alteration" -- a change in the essential nature of the entity's programs or services -- is not required. For example:

- At a museum's gift shop, accompanying and assisting a customer who uses a wheelchair may not be reasonable when there is only one person on duty.

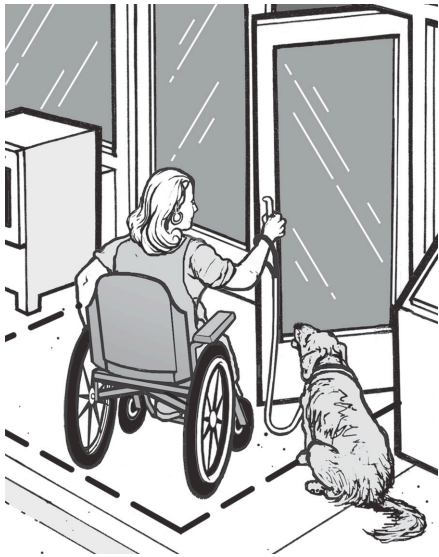

Woman using a wheelchair and her service animal enter a town building

sary to accommodate people who have disabilities. Service animals must be allowed in all areas of a facility where the public is allowed except where the dog's presence would create a legitimate safety risk (e.g., compromise a sterile environment such as a burn treatment unit) or would fundamentally alter the nature of a public entity's services (e.g., allowing a service animal into areas of a zoo where animals that are natural predators or prey of dogs are displayed and the dog's presence would be disruptive). The ADA does not override public health rules that prohibit dogs in swimming pools, but they must be permitted everywhere else.

The ADA requires that service animals be under the control of the handler at all times and be harnessed, leashed, or tethered, unless these devices interfere with the service animal's work or the individual's disability prevents him from using these devices. Individuals who cannot use such devices must maintain control of the animal through voice, signal, or other effective controls.

Public entities may exclude service animals only if 1) the dog is out of control and the handler cannot or does not regain control; or 2) the dog is not housebroken. If a service animal is excluded, the individual must be allowed to enter the facility without the service animal.

Public entities may not require documentation, such as proof that the animal has been certified, trained, or licensed as a service animal, as a condition for entry. In situations where it is not apparent that the dog is a service animal, a public entity may ask only two questions: 1) is the animal required because of a disability? and 2) what work or task has the dog been trained to perform? Public entities may not ask about the nature or extent of an individual's disability.

The ADA does not restrict the breeds of dogs that may be used as service animals. Therefore, a town ordinance that prohibits certain breeds must be modified to allow a person with a disability to use a service animal of a prohibited breed, unless the dog's presence poses a direct threat to the health or safety of others. Public entities have the right to determine, on a case-by-case basis, whether use of a particular service animal poses a direct threat, based on that animal's actual behavior or history; they may not, however, exclude a service animal based solely on fears or generalizations about how an animal or particular breed might behave.

The ADA does not require service animals to be certified, licensed, or registered as a service animal. Nor are they required to wear service animal vests or patches, or to use a specific type of harness. There are individuals and organizations that sell service animal certification or registration documents to the public. The Department of Justice does not recognize these as proof that the dog is a service animal under the ADA.

For additional information, see [ADA 2010 Revised Requirements: Service Animals](http://www.ada.gov/service_animals_2010.htm) at [www.ada.gov/service\\_animals\\_2010.pdf](http://www.ada.gov/service_animals_2010.pdf).



## Wheelchairs and Other Power-Driven Mobility Devices

Allowing mobility devices into a facility is another type of “reasonable modification” necessary to accommodate people who have disabilities.

People with mobility, circulatory, or respiratory disabilities use a variety of devices for mobility. Some use walkers, canes, crutches, or braces while others use manual or power wheelchairs or electric scooters, all of which are primarily designed for use by people with disabilities. Public entities must allow people with disabilities who use these devices into all areas where the public is allowed to go.

Advances in technology have given rise to new power-driven devices that are not necessarily designed specifically for people with disabilities, but are being used by some people with disabilities for mobility. The term “other power-driven mobility devices” is used in the ADA regulations to refer

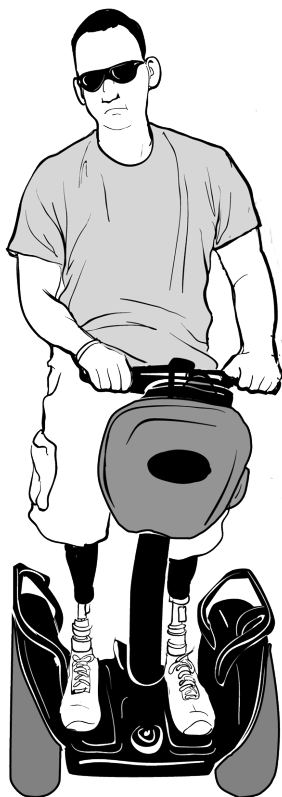

Man with prosthetic legs using a Segway®

to any mobility device powered by batteries, fuel, or other engines, whether or not they are designed primarily for use by individuals with mobility disabilities for the purpose of locomotion. Such devices include Segways®, golf cars, and other devices designed to operate in non-pedestrian areas. Public entities must allow individuals with disabilities who use these devices into all areas where the public is allowed to go, unless the entity can demonstrate that the particular type of device cannot be accommodated because of legitimate safety requirements. Such safety requirements must be based on actual risks, not on speculation or stereotypes about a particular class of devices or how individuals will operate them.

Public entities must consider these factors in determining whether to permit other power-driven mobility devices on their premises:

- the type, size, weight, dimensions, and speed of the device;
- the volume of pedestrian traffic (which may vary at different times of the day, week, month, or year);
- the facility’s design and operational characteristics, such as its square footage, whether it is indoors or outdoors, the placement of stationary equipment, devices, or furniture, and whether it has storage space for the device if requested by the individual;
- whether legitimate safety standards can be established to permit the safe operation of the device; and
- whether the use of the device creates a substantial risk of serious harm to the environment or natural or cultural resources or poses a conflict with Federal land management laws and regulations.

Using these assessment factors, a public entity may decide, for example, that it can allow devices like Segways® in a facility, but cannot allow the

use of golf cars, because the facility's corridors or aisles are not wide enough to accommodate these vehicles. It is likely that many entities will allow the use of Segways® generally, although some may determine that it is necessary to restrict their use during certain hours or particular days when pedestrian traffic is particularly dense. It is also likely that public entities will prohibit the use of combustion-powered devices from all indoor facilities and perhaps some outdoor facilities. Entities are encouraged to develop written policies specifying which power-driven mobility devices will be permitted and where and when they can be used. These policies should be communicated clearly to the public.

Public entities may not ask individuals using such devices about their disability but may ask for a credible assurance that the device is required because of a disability. If the person presents a valid, State-issued disability parking placard or card or a State-issued proof of disability, that must be accepted as credible assurance on its face. If the person does not have this documentation, but states verbally that the device is being used because of a mobility disability, that also must be accepted as credible assurance, unless the person is observed doing something that contradicts the assurance. For example, if a person is observed running and jumping, that may be evidence that contradicts the person's assertion of a mobility disability. However, the fact that a person with a disability is able to walk for some distance does not necessarily contradict a verbal assurance -- many people with mobility disabilities can walk, but need their mobility device for longer distances or uneven terrain. This is particularly true for people who lack stamina, have poor balance, or use mobility devices because of respiratory, cardiac, or neurological disabilities.

For additional information, see [ADA 2010 Revised Requirements: Wheelchairs, Mobility Aids, and Other Power-Driven Mobility Devices](http://www.ada.gov/opdmd.htm) at [www.ada.gov/opdmd.htm](http://www.ada.gov/opdmd.htm) or [www.ada.gov/opdmd.pdf](http://www.ada.gov/opdmd.pdf).

## Communicating with People Who Have Disabilities

Communicating successfully is an essential part of providing service to the public. The ADA requires public entities to take the steps necessary to communicate effectively with people who have disabilities, and uses the term "auxiliary aids and services" to refer to readers, notetakers, sign language interpreters, assistive listening systems and devices, open and closed captioning, text telephones (TTYs), videophones, information provided in large print, Braille, audible, or electronic formats, and other tools for people who have communication disabilities. In addition, the regulations permit the use of newer technologies including real-time captioning (also known as computer-assisted real-time transcription, or CART) in which a transcriber types what is being said at a meeting or event into a computer that projects the words onto a screen; remote CART (which requires an audible feed and a data feed to an off-site transcriber); and video remote interpreting (VRI), a fee-based service that allows public entities that have video conferencing equipment to access a sign language interpreter off-site. Entities that choose to use VRI must comply with specific performance standards set out in the regulations.

Because the nature of communications differs from program to program, the rules allow for flexibility in determining effective communication solutions. The goal is to find a practical solution that fits the circumstances, taking into consideration the nature, length, and complexity of the communication as well as the person's normal method(s) of communication. What is required to communicate effectively when a person is registering for classes at a public university is very different from what is required to communicate effectively in a court proceeding.

Some simple solutions work in relatively simple and straightforward situations. For example:

- If a person who is deaf is paying a parking ticket at the town clerk's office and has a question, exchanging written notes may be effective.
- If a person who is blind needs a document that is short and straightforward, reading it to him may be effective.

Other solutions may be needed where the information being communicated is more extensive or complex. For example:

- If a person who is deaf is attending a town council meeting, effective communication would likely require a sign language interpreter or real time captioning, depending upon whether the person's primary language is sign language or English.
- If a person who is blind needs a longer document, such as a comprehensive emergency preparedness guide, it may have to be provided in an alternate format such as Braille or electronic disk. People who do not read Braille or have access to a computer may need an audiotaped version of the document.

Public entities are required to give primary consideration to the type of auxiliary aid or service requested by the person with the disability. They must honor that choice, unless they can demonstrate that another equally effective means of communication is available or that the aid or service requested would fundamentally alter the nature of the program, service, or activity or would result in undue financial and administrative burdens. If the choice expressed by the person with a disability would result in an undue burden or a fundamental alteration, the public entity still has an obligation to provide another aid or service that provides effective communication, if possible.

The decision that a particular aid or service would result in an undue burden or fundamental alteration must be made by a high level official, no lower than a Department head, and must be accompanied by a written statement of the reasons for reaching that conclusion.

The telecommunications relay service (TRS), reached by calling 7-1-1, is a free nationwide network that uses communications assistants (also called CAs or relay operators) to serve as intermediaries between people who have hearing or speech disabilities who use a text telephone (TTY) or text messaging and people who use standard voice telephones. The communications assistant tells the voice telephone user what the TTY-user is typing and types to the TTY-user what the telephone user is saying. When a person who speaks with difficulty is using a voice telephone, the communications assistant listens and then verbalizes that person's words to the other party. This is called speech-to-speech transliteration.

Video relay service (VRS) is a free, subscriber-based service for people who use sign language and have videophones, smart phones, or computers with video communication capabilities. For outgoing calls, the subscriber contacts the VRS interpreter, who places the call and serves as an intermediary between the subscriber and a person who uses a voice telephone. For incoming calls, the call is automatically routed to the subscriber through the VRS interpreter.

Staff who answer the telephone must accept and treat relay calls just like other calls. The communications assistant or interpreter will explain how the system works.

For additional information, including the performance standards for VRI, see [ADA 2010 Revised Requirements: Effective Communication](http://www.ada.gov/effective-comm.htm) at [www.ada.gov/effective-comm.htm](http://www.ada.gov/effective-comm.htm) or [www.ada.gov/effective-comm.pdf](http://www.ada.gov/effective-comm.pdf).

## MAKING THE BUILT ENVIRONMENT ACCESSIBLE

---

The ADA's regulations and the ADA Standards for Accessible Design, originally published in 1991, set the minimum standard for what makes a facility accessible. Only elements that are built-in (fixed in place) are addressed in the Standards. While the updated 2010 Standards, which became effective on March 15, 2012, retain many of the original provisions in the 1991 Standards, there are some significant differences. The Standards are used when determining if a public entity's programs or services are accessible under the ADA. However, they apply differently depending on whether the entity is providing access to programs or services in existing facilities or is altering an existing facility or building a new facility.

### Access to Programs and Services in Existing Facilities

Public entities have an ongoing obligation to ensure that individuals with disabilities are not excluded from programs and services because facilities are unusable or inaccessible to them. There is no "grandfather clause" in the ADA that exempts older facilities. However, the law strikes a careful balance between increasing access for people with disabilities and recognizing the constraints many public entities face. It allows entities confronted with limited financial resources to improve accessibility without excessive expense.

In the years since the ADA took effect, public facilities have become increasingly accessible. In the event that changes still need to be made, there is flexibility in deciding how to meet this obligation -- structural changes can be made to provide access, the program or service can be relocated to an accessible facility, or the program or service can be provided in an alternate manner. For example:

- In an elementary school without an elevator, a teacher can be assigned to a first floor classroom if the class includes a student with a mobility disability.
- A social service agency located in an inaccessible facility can make arrangements to meet with an applicant or client with a mobility disability at an alternate location that is accessible.
- If an application for a particular city program must be made in person at an inaccessible office, the city could allow a person with a mobility disability to complete and submit the application by mail or email.
- If a public library is inaccessible, staff can provide curbside service for a patron with a mobility disability to check out and return books.

Structural changes are not required where other solutions are feasible. However, where other solutions are not feasible, structural changes are required. When structural change is the method chosen to make a program or service accessible, the changes must meet the requirements of the 2010 ADA Standards, unless it is technically infeasible to do so. When full compliance is not technically feasible, the changes must follow the Standards to the maximum extent feasible. For example, if there is not enough space to install a ramp with a slope that complies with the Standards, a public entity may install a ramp with a slightly steeper slope. However, deviations from the Standards must not pose a significant safety risk. In addition, public entities are not required to take any action that would threaten or destroy the historic significance of an historic property.

Whatever method is chosen, the public entity must ensure that people with disabilities have access to programs and services under the same terms and conditions as other people. For example:

- If a social service agency meets with clients in a private office on the second floor of a building without an elevator, a public area on the first floor is not an acceptable alternate location to meet with a client who has a mobility disability. The alternate location must provide the same degree of privacy as the regular location.
- If a court has ordered a person with a mobility disability to participate in a group anger-management program, and the program is located in an inaccessible facility, it is not acceptable to offer the program to him individually in an accessible location, because the group interaction is a critical component of the program.

There are limits to a public entity's program access obligations. Entities are not required to take any action that would result in undue financial and administrative burdens. The decision that an action would result in an undue burden must be made by a high level official, no lower than a Department head, having budgetary authority and responsibility for making spending decisions, after considering all resources available for use in the funding and operation of the service, program, or activity, and must be accompanied by a written statement of the reasons for reaching that conclusion. If an action would result in an undue burden, a public entity must take any other action that would not result in an undue burden but would nevertheless ensure that individuals with disabilities receive the benefits or services provided by the public entity.

A key concept is that public programs and services, when viewed in their entirety, must be accessible to people with disabilities, but not all facilities must necessarily be made accessible. For example, if a city has multiple public swimming pools and limited resources, it can decide which pools to make accessible based on factors such as the geographic distribution of the sites, the availability of public transportation, the hours of operation, and

the particular programs offered at each site so that the swimming program as a whole is accessible to and usable by people with disabilities.

Another key concept is that public entities have an ongoing obligation to make programs and services accessible to people with disabilities. This means that if many access improvements are needed, and there are insufficient resources to accomplish them in a single year, they can be spread out over time. It also means that rising or falling revenues can affect whether or not an access improvement can be completed in a given year. What might have been seen as an undue burden during an economic downturn could become possible when the economy improves and revenues increase. Thus, public entities should periodically reassess what steps they can take to make their programs and services accessible. Public entities should also consult with people with disabilities in setting priorities for achieving program access. (See **Planning for Success** on page 14.)

Temporary access interruptions for maintenance, repair, or operational activities are permitted, but must be remedied as soon as possible and may not extend beyond a reasonable period of time. Staff must be prepared to assist individuals with disabilities during these interruptions. For example, if the accessible route to a biology lab is temporarily blocked by chairs from a classroom that is being cleaned, staff must be available to move the chairs so a student who uses a wheelchair can get to the lab. In addition, if an accessible feature such as an elevator breaks down, public entities must ensure that repairs are made promptly and that improper or inadequate maintenance does not cause repeated failures. Entities must also ensure that no new barriers are created that impede access by people with disabilities. For example, routinely storing a garbage bin or piling snow in accessible parking spaces makes them unusable and inaccessible to people with mobility disabilities.

For activities that take place infrequently, such as voting, temporary measures can be used to achieve access for individuals who have mobility disabilities. For more information, see [Solutions for Five Common ADA Access Problems at Polling Places](http://www.ada.gov/ada_voting/voting_solutions_ta/polling_place_solutions.htm) at [www.ada.gov/ada\\_voting/voting\\_solutions\\_ta/polling\\_place\\_solutions.htm](http://www.ada.gov/ada_voting/voting_solutions_ta/polling_place_solutions.htm) or [www.ada.gov/ada\\_voting/voting\\_solutions\\_ta/polling\\_place\\_solutions.pdf](http://www.ada.gov/ada_voting/voting_solutions_ta/polling_place_solutions.pdf).

## Element-by-Element Safe Harbor for Existing Facilities

The requirements in the 2010 ADA Standards are, for many building elements, identical to the 1991 Standards and the earlier Uniform Federal Accessibility Standards (UFAS). For some elements, however, the requirements in the 2010 Standards have changed. For example:

- The 1991 Standards allowed light switches, thermostats, and other controls to be installed at a maximum height of 54 inches. Under the 2010 Standards, the maximum height is 48 inches.
- The 1991 Standards required one van-accessible space for every eight accessible spaces. The 2010 Standards require one van-accessible space for every six accessible spaces.
- The 2010 Standards for assembly areas contain revised requirements for dispersion of accessible seating, sightlines over standing spectators, and companion seating.

If a facility was in compliance with the 1991 Standards or UFAS as of March 15, 2012, a public entity is not required to make changes to meet the 2010 Standards. This provision is referred to as the “safe harbor.” It applies on an element-by-element basis and remains in effect until a public entity decides to alter a facility for reasons other than the ADA. For example, if a public entity decides to restripe its parking lot (which is considered an alteration), it must then meet the ratio of van acces-

sible spaces in the 2010 Standards. The ADA’s definition of the term “alteration” is discussed below.

The 2010 Standards also contain requirements for recreational facilities that were not addressed in the 1991 Standards or UFAS. These include swimming pools, play areas, exercise machines, court sport facilities, and boating and fishing piers. Because there were no previous accessibility standards for these types of facilities, the safe harbor does not apply. The program access rules apply, and the 2010 Standards must be followed when structural change is needed to achieve program access.

### New Requirements in the 2010 Standards Not Subject to the Safe Harbor

- Amusement rides
- Recreational boating facilities
- Exercise machines and equipment
- Fishing piers and platforms
- Golf facilities
- Miniature golf facilities
- Play areas
- Saunas and steam rooms
- Swimming pools, wading pools, and spas
- Shooting facilities with firing positions
- Residential facilities and dwelling units
- Miscellaneous
  - Team or player seating
  - Accessible route to bowling lanes
  - Accessible route in court sports

## Alterations

When a public entity chooses to alter any of its facilities, the elements and spaces being altered must comply with the 2010 Standards. An alteration is defined as remodeling, renovating, rehabilitating, reconstructing, changing or rearranging structural parts or elements, changing or rearranging plan configuration of walls and full-height or other fixed partitions, or making other changes that affect (or could affect) the usability of the facility. Examples include restriping a parking lot, moving walls, moving a fixed ATM to another location, installing a new service counter or display shelves, changing a doorway entrance, or replacing fixtures, flooring or carpeting. Normal maintenance, reroofing, painting, wallpapering, or other changes that do not affect the usability of a facility are not considered alterations. The 2010 Standards set minimum accessibility requirements for alterations. In situations where strict compliance with the Standards is technically infeasible, the entity must comply to the maximum extent feasible. "Technically infeasible" is defined as something that has little likelihood of being accomplished because existing structural conditions would require removing or altering a load-bearing member that is an essential part of the structural frame; or because other existing physical or site constraints prohibit modifications or additions that comply fully with the Standards. The 2010 Standards also contain an exemption for certain alterations that would threaten or destroy the historic significance of an historic property.

## New Construction

The ADA requires that all new facilities built by public entities must be accessible to and usable by people with disabilities. The 2010 Standards set out the minimum accessibility requirements for newly constructed facilities.

## 2010 ADA Standards Basics

Chapter 1: Application and Administration. This chapter contains important introductory and interpretive information, including definitions for key terms used in the 2010 Standards.

Chapter 2: Scoping. This chapter sets forth which elements, and how many of them, must be accessible.

Chapters 3 – 10: Design and Technical Requirements. These chapters provide design and technical specifications for elements, spaces, buildings, and facilities.

### Common Provisions

Accessible Routes -- Section 206 and Chapter 4.

Parking Spaces -- Sections 208 and 502. The provisions regarding accessible routes (section 206), signs (section 216), and, where applicable, valet parking (section 209) also apply.

Passenger Loading Zones -- Sections 209 and 503.

Assembly Areas -- Sections 221 and 802.

Sales and Service -- Sections 227 and 904.

Dining and Work Surfaces -- Sections 226 and 902. The provisions regarding accessible routes in section 206.2.5 (Restaurants and Cafeterias) also apply to dining surfaces.

Dressing, Fitting, and Locker Rooms -- Sections 222 and 803.

## Highlights of the 2010 Standards

### Parking

The chart below indicates the number of accessible spaces required by the 2010 Standards. One out of every six accessible spaces must be van-accessible.

Total Number of Parking Spaces Provided in Parking Facility	Minimum Number of Required Accessible Parking Spaces
1 to 25	1
26 to 50	2
51 to 75	3
76 to 100	4
101 to 150	5
151 to 200	6
201 to 300	7
301 to 400	8
401 to 500	9
501 to 1000	2 percent of total

Public entities with very limited parking (four or fewer spaces) must have one van-accessible parking space. However, no signage is required.

An accessible parking space must have an access aisle, which allows a person using a wheelchair or other mobility device to get in and out of the car or van. Accessible parking spaces (including access aisles) must be level (maximum slope 1:48 in all directions) and each access aisle must adjoin an accessible route.

Signage: international symbol of accessibility placed in front of the parking space mounted at least five feet above the ground, measured to the bottom of the sign. Van accessible spaces include the designation "van accessible".

Van Accessible Spaces: 2010 Standards—one for every six accessible spaces (1991 Standards required one for every eight).

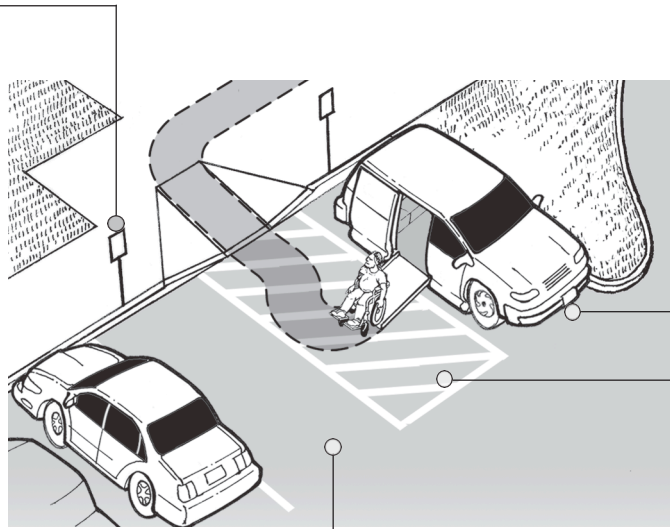

Space width for car: eight feet minimum

Space width for van: minimum 11 feet (although it may be minimum eight feet wide if the access aisle is minimum eight feet wide)

Access Aisle: Width: minimum five feet (if aisle serves car and van spaces)

Length: full length of vehicle parking space

### An overview of accessible parking requirements



## Accessible Entrances

One small step at an entrance can make it impossible for individuals using wheelchairs, walkers, canes, or other mobility devices to enter a public facility. Removing this barrier may be accomplished in a number of ways, such as installing a ramp or a lift or regrading the walkway to provide an accessible route. If the main entrance cannot be made accessible, an alternate accessible entrance can be used. If there are several entrances and only one is accessible, a sign should be posted at the inaccessible entrances directing individuals to the accessible entrance. This entrance must be open whenever other public entrances are open.



Sign at an inaccessible entrance identifies the location of the nearest accessible entrance

## Accessible Routes to Programs and Services

The path a person with a disability takes to enter and move through a facility is called an “accessible route.” This route, which must be at least three feet wide, must remain accessible and not be blocked by items such as vending or ice machines, newspaper dispensers, furniture, filing cabinets, display racks, or potted plants. Similarly, accessible toilet stalls and accessible service counters must not be cluttered with materials or supplies. The accessible route should be the same, or be located in the same area as, the general route used by people without mobility disabilities.

## Shelves, Sales and Service Counters, and Check-Out Aisles

The obligation to provide program access also applies to merchandise shelves, sales and service counters, and check-out aisles. Shelves used by the public must be on an accessible route with enough space to allow individuals using mobility devices to access merchandise or materials. However, shelves may be of any height since they are not subject to the ADA’s reach range requirements. A portion of sales and service counters must be accessible to people who use mobility devices. If a facility has check-out aisles, at least one must be usable by people with mobility disabilities, though more are required in larger venues.

---

## PLANNING FOR SUCCESS

---

Being proactive is the best way to ensure ADA compliance. Many public entities have adopted a general ADA nondiscrimination policy, a specific policy on service animals, a specific policy on effective communication, or specific policies on other ADA topics. Staff also need instructions about how to access the auxiliary aids and services needed to communicate with people who have vision, hearing, or speech disabilities. Public entities should also make staff aware of the free information resources for answers to ADA questions. And officials should be familiar with the 2010 Standards before undertaking any alterations or new construction projects. Training staff on the ADA, conducting periodic self-evaluations of the accessibility of the public entity’s policies, programs and facilities, and developing a transition plan to remove barriers are other proactive steps to ensure ADA compliance.

## ADA Coordinator, Grievance Procedure, Self-Evaluations, and Transition Plans

Public entities that have 50 or more employees are required to have a grievance procedure and to designate at least one responsible employee to coordinate ADA compliance. Although the law does not require the use of the term “ADA Coordinator,” it is commonly used by state and local governments across the country. The ADA Coordinator’s role is to coordinate the government entity’s efforts to comply with the ADA and investigate any complaints that the entity has violated the ADA. The Coordinator serves as the point of contact for individuals with disabilities to request auxiliary aids and services, policy modifications, and other accommodations or to file a complaint with the entity; for the general public to address ADA concerns; and often for other departments and employees of the public entity. The name, office address, and telephone number of the ADA Coordinator must be provided to all interested persons.

The 1991 ADA regulation required all public entities, regardless of size, to evaluate all of their services, policies, and practices and to modify any that did not meet ADA requirements. In addition, public entities with 50 or more employees were required to develop a transition plan detailing any structural changes that would be undertaken to achieve program access and specifying a time frame for their completion. Public entities were also required to provide an opportunity for interested individuals to participate in the self-evaluation and transition planning processes by submitting comments. While the 2010 regulation does not specifically require public entities to conduct a new self-evaluation or develop a new transition plan, they are encouraged to do so.

For more information, see [ADA Best Practices Tool Kit for State and Local Governments](http://www.ada.gov/pcatoolkit/chap2toolkit.htm) at [www.ada.gov/pcatoolkit/chap2toolkit.htm](http://www.ada.gov/pcatoolkit/chap2toolkit.htm).

## Staff Training

A critical, but often overlooked, component of ensuring success is comprehensive and ongoing staff training. Public entities may have good policies, but if front line staff or volunteers are not aware of them or do not know how to implement them, problems can arise. It is important that staff -- especially front line staff who routinely interact with the public -- understand the requirements on modifying policies and practices, communicating with and assisting customers, accepting calls placed through the relay system, and identifying alternate ways to provide access to programs and services when necessary to accommodate individuals with a mobility disability. Many local disability organizations, including Centers for Independent Living, conduct ADA trainings in their communities. The Department of Justice or the National Network of ADA Centers can provide local contact information for these organizations.

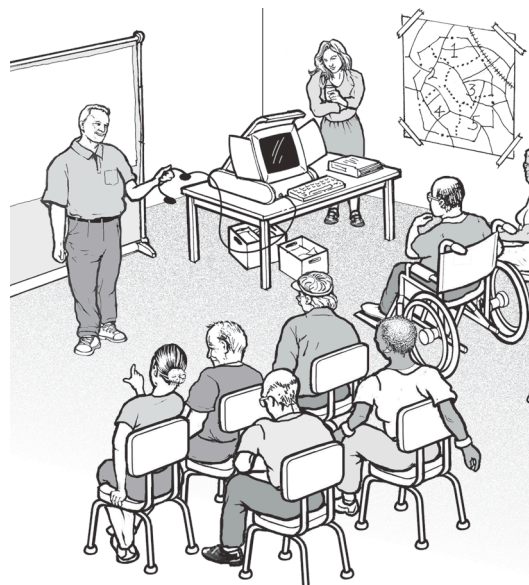

Staff training session for front line staff and volunteers

## ADA INFORMATION RESOURCES

---

### **U.S. Department of Justice**

For more information about the revised ADA regulations and the 2010 Standards, please visit the Department of Justice's website or call our toll-free number.

**ADA Website**  
[www.ADA.gov](http://www.ADA.gov)

**ADA Information Line**  
800-514-0301 (Voice)  
800-514-0383 (TTY)

24 hours a day to order publications by mail.  
M-W, F 9:30 a.m. – 5:30 p.m., Th 12:30 p.m.  
– 5:30 p.m. (Eastern Time) to speak to an ADA Specialist. Calls are confidential.

### **National Network of ADA Centers**

Ten regional centers are funded by the U.S. Department of Education to provide ADA technical assistance to businesses, States and localities, and people with disabilities. One toll-free number connects you to the center in your region:

800-949-4232 (Voice and TTY)

[www.adata.org](http://www.adata.org)

### **Access Board**

For technical assistance on the ADA/ABA Guidelines:

800-872-2253 (Voice)  
800-993-2822 (TTY)

[www.access-board.gov](http://www.access-board.gov)

This publication is available in alternate formats for people with disabilities.

Duplication of this document is encouraged.

June 2015

The logo for ADA Requirements, consisting of the letters "ADA" in a large, bold, sans-serif font above the word "Requirements" in a smaller, bold, sans-serif font, all contained within a dark grey rectangular box with a white arrow pointing to the right.

## ADA Requirements

# Wheelchairs, Mobility Aids, and Other Power-Driven Mobility Devices

## Overview

The Department of Justice published revised final regulations implementing the Americans with Disabilities Act (ADA) for title II (State and local government services) and title III (public accommodations and commercial facilities) on September 15, 2010, in the Federal Register. These requirements, or rules, clarify and refine issues that have arisen over the past 20 years and contain new, and updated, requirements, including the 2010 Standards for Accessible Design (2010 Standards).

**People with mobility, circulatory, respiratory, or neurological disabilities use many kinds of devices for mobility. Some use walkers, canes, crutches, or braces. Some use manual or power wheelchairs or electric scooters. In addition, advances in technology have given rise to new devices, such as Segways®, that some people with disabilities use as mobility devices, including many veterans injured while serving in the military. And more advanced devices will inevitably be invented, providing more mobility options for people with disabilities.**

This publication is designed to help title II entities (State and local governments) and title III entities (businesses and non-profit organizations that serve the public) (together, “covered entities”) understand how the new rules for mobility devices apply to them. These rules went into effect on March 15, 2011.

- s Covered entities must allow people with disabilities who use manual or power wheelchairs or scooters, and manually-powered mobility aids such as walkers, crutches, and canes, into all areas where members of the public are allowed to go.
- s Covered entities must also allow people with disabilities who use other types of power-driven mobility devices into their facilities, unless a particular type of device cannot be accommodated because of legitimate safety requirements. Where legitimate safety requirements bar accommodation for a particular type of device, the covered entity must provide the service it offers in alternate ways if possible.

## Other Power Driven Mobility Devices

s The rules set out five specific factors to consider in deciding whether or not a particular type of device can be accommodated.

ity, different rules apply under the ADA than when it is being used by a person without a disability.

### Wheelchairs

Most people are familiar with the manual and power wheelchairs and electric scooters used by people with mobility disabilities. The term “wheelchair” is defined in the new rules as “a manually-operated or power-driven device designed primarily for use by an individual with a mobility disability for the main purpose of indoor or of both indoor and outdoor locomotion.”

### Other Power-Driven Mobility Devices

In recent years, some people with mobility disabilities have begun using less traditional mobility devices such as golf cars or Segways®. These devices are called “other power-driven mobility device” (OPDMD) in the rule. OPDMD is defined in the new rules as “any mobility device powered by batteries, fuel, or other engines . . . that is used by individuals with mobility disabilities for the purpose of locomotion, including golf cars, electronic personal assistance mobility devices . . . such as the Segway® PT, or any mobility device designed to operate in areas without defined pedestrian routes, but that is not a wheelchair”. When an OPDMD is being used by a person with a mobility disability,

### Choice of Device

People with disabilities have the right to choose whatever mobility device best suits their needs. For example, someone may choose to use a manual wheelchair rather than a power wheelchair because it enables her to maintain her upper body strength. Similarly, someone who is able to stand may choose to use a Segway® rather than a manual wheelchair because of the health benefits gained by standing. A facility may be required to allow a type of device that is generally prohibited when being used by someone without a disability when it is being used by a person who needs it because of a mobility disability. For example, if golf cars are generally prohibited in a park, the park may be required to allow a golf car when it is being used because of a person’s mobility disability, unless there is a legitimate safety reason that it cannot be accommodated.

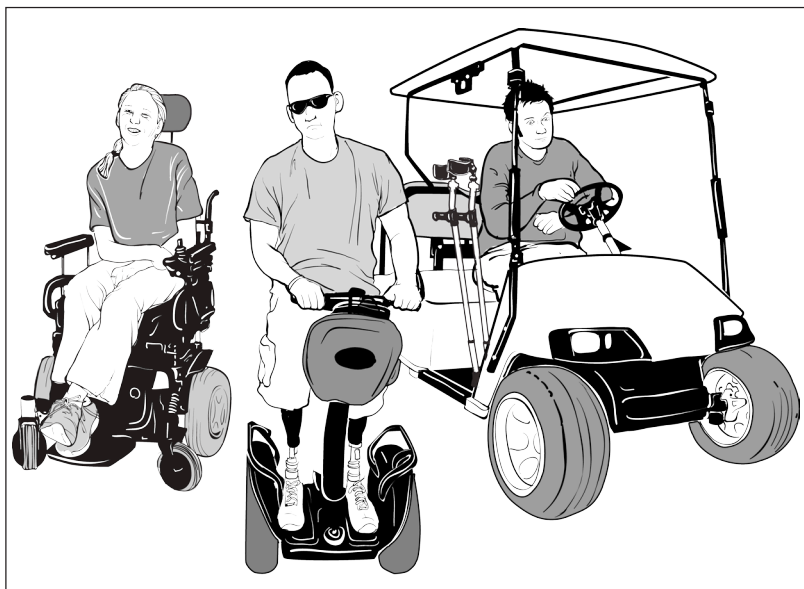

## Requirements Regarding Mobility Devices and Aids

Under the new rules, covered entities must allow people with disabilities who use wheelchairs (including manual wheelchairs, power wheelchairs, and electric scooters) and manually-powered mobility aids such as walkers, crutches, canes, braces, and other similar devices into all areas of a facility where members of the public are allowed to go.

In addition, covered entities must allow people with disabilities who use any OPDMD to enter the premises unless a particular type of device cannot be accommodated because of legitimate safety requirements. Such safety requirements must be based on actual risks, not on speculation or stereotypes about a particular type of device or how it might be operated by people with disabilities using them.

- s For some facilities -- such as a hospital, a shopping mall, a large home improvement store with wide aisles, a public park, or an outdoor amusement park -- covered entities will likely determine that certain classes of OPDMDs being used by people with disabilities can be accommodated. These entities must allow people with disabilities using these types of OPDMDs into all areas where members of the public are allowed to go.
- s In some cases, even in facilities such as those described above, an OPDMD can be

accommodated in some areas of a facility, but not in others because of legitimate safety concerns. For example, a cruise ship may decide that people with disabilities using Segways® can generally be accommodated, except in constricted areas, such as passageways to cabins that are very narrow and have low ceilings.

- s For other facilities -- such as a small convenience store, or a small town manager's office -- covered entities may determine that certain classes of OPDMDs cannot be accommodated. In that case, they are still required to serve a person with a disability using one of these devices in an alternate manner if possible, such as providing curbside service or meeting the person at an alternate location.

Covered entities are encouraged to develop written policies specifying which kinds of OPDMDs will be permitted and where and when they will be permitted, based on the following assessment factors.



### Assessment Factors

In deciding whether a particular type of OPDMD can be accommodated in a particular facility, the following factors must be considered:

- s the type, size, weight, dimensions, and speed of the device;
- s the facility's volume of pedestrian traffic (which may vary at different times of the day, week, month, or year);
- s the facility's design and operational characteristics (e.g., whether its business is conducted indoors or outdoors, its square footage, the density and placement of furniture and other stationary devices, and the availability of storage for the OPDMD if needed and requested by the user);

- s whether legitimate safety requirements (such as limiting speed to the pace of pedestrian traffic or prohibiting use on escalators) can be established to permit the safe operation of the OPDMD in the specific facility; and
- s whether the use of the OPDMD creates a substantial risk of serious harm to the immediate environment or natural or cultural resources, or poses a conflict with Federal land management laws and regulations.

It is important to understand that these assessment factors relate to an entire class of device type, *not* to how a person with a disability might operate the device. (See next topic for operational issues.) All types of devices powered by fuel or combustion engines, for example, may be excluded from indoor settings for health or environmental reasons, but may be deemed acceptable in some outdoor settings. Also, for safety reasons, larger electric devices such as golf cars may be excluded from narrow or crowded settings where there is no valid reason to exclude smaller electric devices like Segways®.

Based on these assessment factors, the Department of Justice expects that devices such as Segways® can be accommodated in most circumstances. The Department also expects that, in most circumstances, people with disabilities using ATVs and other combustion engine-driven devices may be prohibited indoors and in outdoor areas with heavy pedestrian traffic.



## Policies on the Use of OPDMDs

In deciding whether a type of OPDMD can be accommodated, covered entities must consider all assessment factors and, where appropriate, should develop and publicize rules for people with disabilities using these devices.

Such rules may include –

- s requiring the user to operate the device at the speed of pedestrian traffic;
- s identifying specific locations, terms, or circumstances (if any) where the devices cannot be accommodated;
- s setting out instructions for going through security screening machines if the device contains technology that could be harmed by the machine; and
- s specifying whether or not storage is available for the device when it is not being used.

## Credible Assurance

An entity that determines it can accommodate one or more types of OPDMDs in its facility is allowed to ask the person using the device to provide credible assurance that the device is used because of a disability. If the person presents a valid, State-issued disability parking placard or card or a State-issued proof of disability, that must be accepted as credible assurance on its face. If the person does not have this documentation, but states

verbally that the OPDMD is being used because of a mobility disability, that also must be accepted as credible assurance, unless the person is observed doing something that contradicts the assurance. For example, if a person is observed running and jumping, that may be evidence that contradicts the person's assertion of a mobility disability. However, it is very important for covered entities and their staff to understand that the fact that a person with a disability is able to walk for a short distance does not necessarily contradict a verbal assurance -- many people with mobility disabilities can walk, but need their mobility device for longer distances or uneven terrain. This is particularly true for people who lack stamina, have poor balance, or use mobility devices because of respiratory, cardiac, or neurological disabilities. A covered entity cannot ask people about their disabilities.





## Staff Training

Ongoing staff training is essential to ensure that people with disabilities who use OPDMDs for mobility are not turned away or treated inappropriately. Training should include instruction on the types of OPDMDs that can be accommodated, the rules for obtaining credible assurance that the device is being used because of a disability, and the rules for operation of the devices within the facility.

**For more information about the ADA,  
please visit our website  
or call our toll-free number.**

**ADA Website:** [www.ADA.gov](http://www.ADA.gov)

To receive e-mail notifications when new ADA information is available, visit the ADA Website and click on the link near the bottom of the right-hand column.

### **ADA Information Line**

800-514-0301 (Voice) and  
800-514-0383 (TTY)

Call M-W, F 9:30 a.m. – 5:30 p.m., Th  
12:30 p.m. – 5:30 p.m. (Eastern Time) to  
speak with an ADA Specialist (calls are  
confidential) or call 24 hours a day to  
order publications by mail.

For people with disabilities,  
this publication is available  
in alternate formats.

Duplication of this document  
is encouraged.

January 2014

U.S. Department of Justice  
Civil Rights Division  
Disability Rights Section

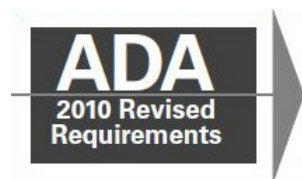

## Service Animals

The Department of Justice published revised final regulations implementing the Americans with Disabilities Act (ADA) for title II (State and local government services) and title III (public accommodations and commercial facilities) on September 15, 2010, in the Federal Register. These requirements, or rules, clarify and refine issues that have arisen over the past 20 years and contain new, and updated, requirements, including the 2010 Standards for Accessible Design (2010 Standards).

### Overview

This publication provides guidance on the term “service animal” and the service animal provisions in the Department’s new regulations.

- Beginning on March 15, 2011, only dogs are recognized as service animals under titles II and III of the ADA.
- A service animal is a dog that is individually trained to do work or perform tasks for a person with a disability.
- Generally, title II and title III entities must permit service animals to accompany people with disabilities in all areas where members of the public are allowed to go.

### How “Service Animal” Is Defined

**Service animals are defined as dogs that are individually trained to do work or perform tasks for people with disabilities.** Examples of such work or tasks include guiding people who are blind, alerting people who are deaf, pulling a wheelchair, alerting and protecting a person who is having a seizure, reminding a person with mental illness to take prescribed medications, calming a person with Post Traumatic Stress Disorder (PTSD) during an anxiety attack, or performing other duties. Service animals are working animals, not pets. The work or task a dog has been trained to provide must be directly related to the person’s disability. Dogs whose sole function is to provide comfort or emotional support do not qualify as service animals under the ADA.

This definition does not affect or limit the broader definition of “assistance animal” under the Fair Housing Act or the broader definition of “service animal” under the Air Carrier Access Act.

Some State and local laws also define service animal more broadly than the ADA does. Information about such laws can be obtained from the State attorney general’s office.

### Where Service Animals Are Allowed

**Under the ADA, State and local governments, businesses, and nonprofit organizations that serve the public generally must allow service animals to accompany people with disabilities in all areas of the facility where the public is normally allowed to go.** For example, in a hospital it would be inappropriate to exclude a service animal from areas such as patient rooms, clinics, cafeterias, or examination rooms. However, it may be appropriate to exclude a service animal from

operating rooms or burn units where the animal's presence may compromise a sterile environment.

## **Service Animals Must Be Under Control**

**Under the ADA, service animals must be harnessed, leashed, or tethered, unless these devices interfere with the service animal's work or the individual's disability prevents using these devices.** In that case, the individual must maintain control of the animal through voice, signal, or other effective controls.

### **Inquiries, Exclusions, Charges, and Other Specific Rules Related to Service Animals**

- When it is not obvious what service an animal provides, only limited inquiries are allowed. Staff may ask two questions: (1) is the dog a service animal required because of a disability, and (2) what work or task has the dog been trained to perform. Staff cannot ask about the person's disability, require medical documentation, require a special identification card or training documentation for the dog, or ask that the dog demonstrate its ability to perform the work or task.
- Allergies and fear of dogs are not valid reasons for denying access or refusing service to people using service animals. When a person who is allergic to dog dander and a person who uses a service animal must spend time in the same room or facility, for example, in a school classroom or at a homeless shelter, they both should be accommodated by assigning them, if possible, to different locations within the room or different rooms in the facility.
- A person with a disability cannot be asked to remove his service animal from the premises unless: (1) the dog is out of control and the handler does not take effective action to control it or (2) the dog is not housebroken. When there is a legitimate reason to ask that a service animal be removed, staff must offer the person with the disability the opportunity to obtain goods or services without the animal's presence.
- Establishments that sell or prepare food must allow service animals in public areas even if state or local health codes prohibit animals on the premises.
- People with disabilities who use service animals cannot be isolated from other patrons, treated less favorably than other patrons, or charged fees that are not charged to other patrons without animals. In addition, if a business requires a deposit or fee to be paid by patrons with pets, it must waive the charge for service animals.
- If a business such as a hotel normally charges guests for damage that they cause, a customer with a disability may also be charged for damage caused by himself or his service animal.
- Staff are not required to provide care or food for a service animal.

## **Miniature Horses**

**In addition to the provisions about service dogs, the Department's revised ADA regulations have a new, separate provision about miniature horses that have been individually trained to do work or perform tasks for people with disabilities.** (Miniature horses generally range in height from 24 inches to 34 inches measured to the shoulders and generally weigh between 70 and 100 pounds.) Entities covered by the ADA must modify their policies to permit miniature horses where reasonable. The regulations set out four assessment factors to assist entities in determining whether miniature horses can be accommodated in their facility. The assessment factors are (1) whether the miniature horse is housebroken; (2) whether the miniature horse is under the owner's control; (3) whether the facility can accommodate the miniature horse's type, size, and weight; and (4) whether the miniature horse's presence will not compromise legitimate safety requirements necessary for safe operation of the facility.

**For more information about the ADA, please visit our website or call our toll-free number.**

**ADA Website**

**[www.ADA.gov](http://www.ADA.gov)**

To receive e-mail notifications when new ADA information is available,

visit the ADA Website's home page and click the [link](#) near the top of the middle column.

**ADA Information Line**

800-514-0301 (Voice) and 800-514-0383 (TTY)

24 hours a day to order publications by mail.

M-W, F 9:30 a.m. – 5:30 p.m., Th 12:30 p.m. – 5:30 p.m. (Eastern Time)

to speak with an ADA Specialist. All calls are confidential.

For persons with disabilities, this publication is available in alternate formats.

Duplication of this document is encouraged. July 2011

---

**PDF Version of this Document**

July 12, 2011



## Frequently Asked Questions about Service Animals and the ADA

Many people with disabilities use a service animal in order to fully participate in everyday life. Dogs can be trained to perform many important tasks to assist people with disabilities, such as providing stability for a person who has difficulty walking, picking up items for a person who uses a wheelchair, preventing a child with autism from wandering away, or alerting a person who has hearing loss when someone is approaching from behind.

The Department of Justice continues to receive many questions about how the Americans with Disabilities Act (ADA) applies to service animals. The ADA requires State and local government agencies, businesses, and non-profit organizations (covered entities) that provide goods or services to the public to make “reasonable modifications” in their policies, practices, or procedures when necessary to accommodate people with disabilities. The service animal rules fall under this general principle. Accordingly, entities that have a “no pets” policy generally must modify the policy to allow service animals into their facilities. This publication provides guidance on the ADA’s service animal provisions and should be read in conjunction with the publication [\*ADA Revised Requirements: Service Animals\*](#).

### DEFINITION OF SERVICEANIMAL

#### **Q1:** What is a service animal?

A: Under the ADA, a service animal is defined as a dog that has been individually trained to do work or perform tasks for an individual with a disability. The task(s) performed by the dog must be directly related to the person’s disability.

#### **Q2:** What does “do work or perform tasks” mean?

A: The dog must be trained to take a specific action when needed to assist the person with a disability. For example, a person with diabetes may have a dog that is trained to alert him when his blood sugar reaches high or low levels. A person with depression may have a dog that is trained to remind her to take her medication. Or, a person who has epilepsy may have a dog that is trained to detect the onset of a seizure and then help the person remain safe during the seizure.

**Q3: Are emotional support, therapy, comfort, or companion animals considered service animals under the ADA?**

A: No. These terms are used to describe animals that provide comfort just by being with a person. Because they have not been trained to perform a specific job or task, they do not qualify as service animals under the ADA. However, some State or local governments have laws that allow people to take emotional support animals into public places. You may check with your State and local government agencies to find out about these laws.

**Q4: If someone's dog calms them when having an anxiety attack, does this qualify it as a service animal?**

A: It depends. The ADA makes a distinction between psychiatric service animals and emotional support animals. If the dog has been trained to sense that an anxiety attack is about to happen and take a specific action to help avoid the attack or lessen its impact, that would qualify as a service animal. However, if the dog's mere presence provides comfort, that would not be considered a service animal under the ADA.

**Q5: Does the ADA require service animals to be professionally trained?**

A: No. People with disabilities have the right to train the dog themselves and are not required to use a professional service dog training program.

**Q6: Are service-animals-in-training considered service animals under the ADA?**

A: No. Under the ADA, the dog must already be trained before it can be taken into public places. However, some State or local laws cover animals that are still in training.

## GENERAL RULES

**Q7: What questions can a covered entity's employees ask to determine if a dog is a service animal?**

A: In situations where it is not obvious that the dog is a service animal, staff may ask only two specific questions: (1) is the dog a service animal required because of a disability? and (2) what work or task has the dog been trained to perform? Staff are not allowed to request any documentation for the dog, require that the dog demonstrate its task, or inquire about the nature of the person's disability.

**Q8: Do service animals have to wear a vest or patch or special harness identifying them as service animals?**

A: No. The ADA does not require service animals to wear a vest, ID tag, or specific harness.

**Q9: Who is responsible for the care and supervision of a service animal?**

A: The handler is responsible for caring for and supervising the service animal, which includes toileting, feeding, and grooming and veterinary care. Covered entities are not obligated to supervise or otherwise care for a service animal.

**Q10:** Can a person bring a service animal with them as they go through a salad bar or other self-service food lines?

A: Yes. Service animals must be allowed to accompany their handlers to and through self-service food lines. Similarly, service animals may not be prohibited from communal food preparation areas, such as are commonly found in shelters or dormitories.

**Q11:** Can hotels assign designated rooms for guests with service animals, out of consideration for other guests?

A: No. A guest with a disability who uses a service animal must be provided the same opportunity to reserve any available room at the hotel as other guests without disabilities. They may not be restricted to "pet-friendly" rooms.

**Q12:** Can hotels charge a cleaning fee for guests who have service animals?

A: No. Hotels are not permitted to charge guests for cleaning the hair or dander shed by a service animal. However, if a guest's service animal causes damages to a guest room, a hotel is permitted to charge the same fee for damages as charged to other guests.

**Q13:** Can people bring more than one service animal into a public place?

A: Generally, yes. Some people with disabilities may use more than one service animal to perform different tasks. For example, a person who has a visual disability and a seizure disorder may use one service animal to assist with way-finding and another that is trained as a seizure alert dog. Other people may need two service animals for the same task, such as a person who needs two dogs to assist him or her with stability when walking. Staff may ask the two permissible questions (See Question 7) about each of the dogs. If both dogs can be accommodated, both should be allowed in. In some circumstances, however, it may not be possible to accommodate more than one service animal. For example, in a crowded small restaurant, only one dog may be able to fit under the table. The only other place for the second dog would be in the aisle, which would block the space between tables. In this case, staff may request that one of the dogs be left outside.

**Q14:** Does a hospital have to allow an in-patient with a disability to keep a service animal in his or her room?

A: Generally, yes. Service animals must be allowed in patient rooms and anywhere else in the hospital the public and patients are allowed to go. They cannot be excluded on the grounds that staff can provide the same services.

**Q15:** What happens if a patient who uses a service animal is admitted to the hospital and is unable to care for or supervise their animal?

A: If the patient is not able to care for the service animal, the patient can make arrangements for a family member or friend to come to the hospital to provide these services, as it is always preferable that the service animal and its handler not to be separated, or to keep the dog during the hospitalization. If the patient is unable to care for the dog and is unable to arrange for someone else to care for the dog, the hospital may place the dog in a boarding facility until the patient is released, or make other appropriate arrangements. However, the hospital must give the patient opportunity to make arrangements for the dog's care before taking such steps.

**Q16: Must a service animal be allowed to ride in an ambulance with its handler?**

A: Generally, yes. However, if the space in the ambulance is crowded and the dog's presence would interfere with the emergency medical staff's ability to treat the patient, staff should make other arrangements to have the dog transported to the hospital.

## **CERTIFICATION AND REGISTRATION**

**Q17: Does the ADA require that service animals be certified as service animals?**

A: No. Covered entities may not require documentation, such as proof that the animal has been certified, trained, or licensed as a service animal, as a condition for entry.

There are individuals and organizations that sell service animal certification or registration documents online. These documents do not convey any rights under the ADA and the Department of Justice does not recognize them as proof that the dog is a service animal.

**Q18: My city requires all dogs to be vaccinated. Does this apply to my service animal?**

A: Yes. Individuals who have service animals are not exempt from local animal control or public health requirements.

**Q19: My city requires all dogs to be registered and licensed. Does this apply to my service animal?**

A: Yes. Service animals are subject to local dog licensing and registration requirements.

**Q20: My city requires me to register my dog as a service animal. Is this legal under the ADA?**

A: No. Mandatory registration of service animals is not permissible under the ADA. However, as stated above, service animals are subject to the same licensing and vaccination rules that are applied to all dogs.

**Q21: My city / college offers a voluntary registry program for people with disabilities who use service animals and provides a special tag identifying the dogs as service animals. Is this legal under the ADA?**

A: Yes. Colleges and other entities, such as local governments, may offer voluntary registries. Many communities maintain a voluntary registry that serves a public purpose, for example, to ensure that emergency staff know to look for service animals during an emergency evacuation process. Some offer a benefit, such as a reduced dog license fee, for individuals who register their service animals. Registries for purposes like this are permitted under the ADA. An entity may not, however, require that a dog be registered as a service animal as a condition of being permitted in public places. This would be a violation of the ADA.



## BREEDS

### **Q22: Can service animals be any breed of dog?**

A: Yes. The ADA does not restrict the type of dog breeds that can be service animals.

### **Q23: Can individuals with disabilities be refused access to a facility based solely on the breed of their service animal?**

A: No. A service animal may not be excluded based on assumptions or stereotypes about the animal's breed or how the animal might behave. However, if a particular service animal behaves in a way that poses a direct threat to the health or safety of others, has a history of such behavior, or is not under the control of the handler, that animal may be excluded. If an animal is excluded for such reasons, staff must still offer their goods or services to the person without the animal present.

### **Q24: If a municipality has an ordinance that bans certain dog breeds, does the ban apply to service animals?**

A: No. Municipalities that prohibit specific breeds of dogs must make an exception for a service animal of a prohibited breed, unless the dog poses a direct threat to the health or safety of others. Under the "direct threat" provisions of the ADA, local jurisdictions need to determine, on a case-by-case basis, whether a particular service animal can be excluded based on that particular animal's actual behavior or history, but they may not exclude a service animal because of fears or generalizations about how an animal or breed might behave. It is important to note that breed restrictions differ significantly from jurisdiction to jurisdiction. In fact, some jurisdictions have no breed restrictions.

## EXCLUSION OF SERVICE ANIMALS

### **Q25: When can service animals be excluded?**

A: The ADA does not require covered entities to modify policies, practices, or procedures if it would "fundamentally alter" the nature of the goods, services, programs, or activities provided to the public. Nor does it overrule legitimate safety requirements. If admitting service animals would fundamentally alter the nature of a service or program, service animals may be prohibited. In addition, if a particular service animal is out of control and the handler does not take effective action to control it, or if it is not housebroken, that animal may be excluded.

### **Q26: When might a service dog's presence fundamentally alter the nature of a service or program provided to the public?**

A: In most settings, the presence of a service animal will not result in a fundamental alteration. However, there are some exceptions. For example, at a boarding school, service animals could be restricted from a specific area of a dormitory reserved specifically for students with allergies to dog dander. At a zoo, service animals can be restricted from areas where the animals on display are the natural prey or natural predators of dogs, where the presence of a dog would be disruptive, causing the displayed animals to behave aggressively or become agitated. They cannot be restricted from other areas of the zoo.

**Q27: What does under control mean? Do service animals have to be on a leash? Do they have to be quiet and not bark?**

A: The ADA requires that service animals be under the control of the handler at all times. In most instances, the handler will be the individual with a disability or a third party who accompanies the individual with a disability. In the school (K-12) context and in similar settings, the school or similar entity may need to provide some assistance to enable a particular student to handle his or her service animal. The service animal must be harnessed, leashed, or tethered while in public places unless these devices interfere with the service animal's work or the person's disability prevents use of these devices. In that case, the person must use voice, signal, or other effective means to maintain control of the animal. For example, a person who uses a wheelchair may use a long, retractable leash to allow her service animal to pick up or retrieve items. She may not allow the dog to wander away from her and must maintain control of the dog, even if it is retrieving an item at a distance from her. Or, a returning veteran who has PTSD and has great difficulty entering unfamiliar spaces may have a dog that is trained to enter a space, check to see that no threats are there, and come back and signal that it is safe to enter. The dog must be off leash to do its job, but may be leashed at other times. Under control also means that a service animal should not be allowed to bark repeatedly in a lecture hall, theater, library, or other quiet place. However, if a dog barks just once, or barks because someone has provoked it, this would not mean that the dog is out of control.

**Q28: What can my staff do when a service animal is being disruptive?**

A: If a service animal is out of control and the handler does not take effective action to control it, staff may request that the animal be removed from the premises.

**Q29: Are hotel guests allowed to leave their service animals in their hotel room when they leave the hotel?**

A: No, the dog must be under the handler's control at all times.

**Q30: What happens if a person thinks a covered entity's staff has discriminated against him or her?**

A: Individuals who believe that they have been illegally denied access or service because they use service animals may file a complaint with the U.S. Department of Justice. Individuals also have the right to file a private lawsuit in Federal court charging the entity with discrimination under the ADA.

## MISCELLANEOUS

**Q31: Are stores required to allow service animals to be placed in a shopping cart?**

A: Generally, the dog must stay on the floor, or the person must carry the dog. For example, if a person with diabetes has a glucose alert dog, he may carry the dog in a chest pack so it can be close to his face to allow the dog to smell his breath to alert him of a change in glucose levels.

**Q32: Are restaurants, bars, and other places that serve food or drink required to allow service animals to be seated on chairs or allow the animal to be fed at the table?**

A: No. Seating, food, and drink are provided for customer use only. The ADA gives a person with a disability the right to be accompanied by his or her service animal, but covered entities are not required to allow an animal to sit or be fed at the table.

**Q33: Are gyms, fitness centers, hotels, or municipalities that have swimming pools required to allow a service animal in the pool with its handler?**

A: No. The ADA does not override public health rules that prohibit dogs in swimming pools. However, service animals must be allowed on the pool deck and in other areas where the public is allowed to go.

**Q34: Are churches, temples, synagogues, mosques, and other places of worship required to allow individuals to bring their service animals into the facility?**

A: No. Religious institutions and organizations are specifically exempt from the ADA. However, there may be State laws that apply to religious organizations.

**Q35: Do apartments, mobile home parks, and other residential properties have to comply with the ADA?**

A: The ADA applies to housing programs administered by state and local governments, such as public housing authorities, and by places of public accommodation, such as public and private universities. In addition, the Fair Housing Act applies to virtually all types of housing, both public and privately-owned, including housing covered by the ADA. Under the Fair Housing Act, housing providers are obligated to permit, as a reasonable accommodation, the use of animals that work, provide assistance, or perform tasks that benefit persons with a disabilities, or provide emotional support to alleviate a symptom or effect of a disability. For information about these Fair Housing Act requirements see HUD's Notice on Service Animals and Assistance Animals for People with Disabilities in Housing and HUD-funded Programs.

**Q36: Do Federal agencies, such as the U.S. Department of Veterans Affairs, have to comply with the ADA?**

A: No. Section 504 of the Rehabilitation Act of 1973 is the Federal law that protects the rights of people with disabilities to participate in Federal programs and services. For information or to file a complaint, contact the agency's equal opportunity office.

**Q37: Do commercial airlines have to comply with the ADA?**

A: No. The Air Carrier Access Act is the Federal law that protects the rights of people with disabilities in air travel. For information or to file a complaint, contact the U.S. Department of Transportation, Aviation Consumer Protection Division, at 202-366-2220.

For more information about the ADA, please visit our website or call our toll-free number.

**ADA Website**

[www.ADA.gov](http://www.ADA.gov)

To receive e-mail notifications when new ADA information is available, visit the ADA Website's home page and click the link near the bottom of the right-hand column.

**ADA Information Line**

800-514-0301 (Voice) and 800-514-0383 (TTY)

24 hours a day to order publications by mail.

M-W, F 9:30 a.m. – 5:30 p.m. , Th 12:30 p.m. – 5:30 p.m. (Eastern Time)  
to speak with an ADA Specialist. Calls are confidential.

For people with disabilities, this publication is available in alternate formats.

Duplication of this document is encouraged.

July 20, 2015

**U.S. Department of Justice**  
Civil Rights Division  
Disability Rights Section



## Effective Communication

The Department of Justice published revised final regulations implementing the Americans with Disabilities Act (ADA) for title II (State and local government services) and title III (public accommodations and commercial facilities) on September 15, 2010, in the Federal Register. These requirements, or rules, clarify and refine issues that have arisen over the past 20 years and contain new, and updated, requirements, including the 2010 Standards for Accessible Design (2010 Standards).

---

### Overview

**People who have vision, hearing, or speech disabilities (“communication disabilities”) use different ways to communicate. For example, people who are blind may give and receive information audibly rather than in writing and people who are deaf may give and receive information through writing or sign language rather than through speech.**

The ADA requires that title II entities (State and local governments) and title III entities (businesses and nonprofit organizations that serve the public) communicate effectively with people who have communication disabilities. The goal is to ensure that communication with people with these disabilities is equally effective as communication with people without disabilities.

This publication is designed to help title II and title III entities (“covered entities”) understand how the rules for effective communication, including rules that went into effect on March 15, 2011, apply to them.

- The purpose of the effective communication rules is to ensure that the person with a vision, hearing, or speech disability can communicate with, receive information from, and convey information to, the covered entity.
- Covered entities must provide auxiliary aids and services when needed to communicate effectively with people who have communication disabilities.
- The key to communicating effectively is to consider the nature, length, complexity, and context of the communication and the person’s normal method(s) of communication.
- The rules apply to communicating with the person who is receiving the covered entity’s goods or services as well as with that person’s parent, spouse, or companion in appropriate circumstances.

---

### Auxiliary Aids and Services

The ADA uses the term “auxiliary aids and services” (“aids and services”) to refer to the ways to communicate with people who have communication disabilities.

- For people who are blind, have vision loss, or are deaf-blind, this includes providing a qualified reader; information in large print, Braille, or electronically for use with a computer screen-reading program; or an audio recording of printed information. A “qualified” reader means someone who is able to read effectively, accurately, and impartially, using any necessary specialized vocabulary.
- For people who are deaf, have hearing loss, or are deaf-blind, this includes providing a qualified notetaker; a qualified sign language interpreter, oral interpreter, cued-speech interpreter, or tactile interpreter; real-time captioning; written

materials; or a printed script of a stock speech (such as given on a museum or historic house tour). A “qualified” interpreter means someone who is able to interpret effectively, accurately, and impartially, both receptively (i.e., understanding what the person with the disability is saying) and expressively (i.e., having the skill needed to convey information back to that person) using any necessary specialized vocabulary.

- For people who have speech disabilities, this may include providing a qualified speech-to-speech transliterator (a person trained to recognize unclear speech and repeat it clearly) , especially if the person will be speaking at length, such as giving testimony in court, or just taking more time to communicate with someone who uses a communication board. In some situations, keeping paper and pencil on hand so the person can write out words that staff cannot understand or simply allowing more time to communicate with someone who uses a communication board or device may provide effective communication. Staff should always listen attentively and not be afraid or embarrassed to ask the person to repeat a word or phrase they do not understand.

In addition, aids and services include a wide variety of technologies including 1) assistive listening systems and devices; 2) open captioning, closed captioning, real-time captioning, and closed caption decoders and devices; 3) telephone handset amplifiers, hearing-aid compatible telephones, text telephones (TTYs) , videophones, captioned telephones, and other voice, text, and video-based telecommunications products; 4) videotext displays; 5) screen reader software, magnification software, and optical readers; 6) video description and secondary auditory programming (SAP) devices that pick up video-described audio feeds for television programs; 7) accessibility features in electronic documents and other electronic and information technology that is accessible (either independently or through assistive technology such as screen readers) .

**Real-time captioning** (also known as computer-assisted real-time transcription, or CART) is a service similar to court reporting in which a transcriber types what is being said at a meeting or event into a computer that projects the words onto a screen. This service, which can be provided on-site or remotely, is particularly useful for people who are deaf or have hearing loss but do not use sign language.

The free nationwide **telecommunications relay service** (TRS), reached by calling 7-1-1, uses communications assistants (also called CAs or relay operators) who serve as intermediaries between people who have hearing or speech disabilities who use a text telephone (TTY) or text messaging and people who use standard voice telephones. The communications assistant tells the telephone user what the other party is typing and types to tell the other party what the telephone user is saying. TRS also provides speech-to-speech transliteration for callers who have speech disabilities.

**Video relay service** (VRS) is a free, subscriber-based service for people who use sign language and have videophones, smart phones, or computers with video communication capabilities. For outgoing calls, the subscriber contacts the VRS interpreter, who places the call and serves as an intermediary between the subscriber and a person who uses a standard voice telephone. The interpreter tells the telephone user what the subscriber is signing and signs to the subscriber what the telephone user is saying.

**Video remote interpreting** (VRI) is a fee-based service that uses video conferencing technology to access an off-site interpreter to provide real-time sign language or oral interpreting services for conversations between hearing people and people who are deaf or have hearing loss. The new regulations give covered entities the choice of using VRI or on-site interpreters in situations where either would be effective. VRI can be especially useful in rural areas where on-site interpreters may be difficult to obtain. Additionally, there may be some cost advantages in using VRI in certain circumstances. However, VRI will not be effective in all circumstances. For example, it will not be effective if the person who needs the interpreter has difficulty seeing the screen (either because of vision loss or because he or she cannot be properly positioned to see the screen, because of an injury or other condition). In these circumstances, an on-site interpreter may be required.

If VRI is chosen, **all** of the following specific performance standards must be met:

- real-time, full-motion video and audio over a dedicated high-speed, wide-bandwidth video connection or wireless connection that delivers high-quality video images that do not produce lags, choppy, blurry, or grainy images, or irregular pauses in communication;
- a sharply delineated image that is large enough to display the interpreter’s face, arms, hands, and fingers, and the face, arms, hands, and fingers of the person using sign language, regardless of his or her body position;

- a clear, audible transmission of voices; and
- adequate staff training to ensure quick set-up and proper operation.

**Many deaf-blind individuals use support service providers (SSPs) to assist them in accessing the world around them. SSPs are not “aids and services” under the ADA. However, they provide mobility, orientation, and informal communication services for deaf-blind individuals and are a critically important link enabling them to independently access the community at large.**

---

## Effective Communication Provisions

---

Covered entities must provide aids and services when needed to communicate effectively with people who have communication disabilities.

The key to deciding what aid or service is needed to communicate **effectively** is to consider the nature, length, complexity, and context of the communication as well as the person’s normal method(s) of communication.

Some easy solutions work in relatively simple and straightforward situations. For example:

- In a lunchroom or restaurant, reading the menu to a person who is blind allows that person to decide what dish to order.
- In a retail setting, pointing to product information or writing notes back and forth to answer simple questions about a product may allow a person who is deaf to decide whether to purchase the product.

Other solutions may be needed where the information being communicated is more extensive or complex. For example:

- In a law firm, providing an accessible electronic copy of a legal document that is being drafted for a client who is blind allows the client to read the draft at home using a computer screen-reading program.
- In a doctor’s office, an interpreter generally will be needed for taking the medical history of a patient who uses sign language or for discussing a serious diagnosis and its treatment options.

A person’s method(s) of communication are also key. For example, sign language interpreters are effective only for people who use sign language. Other methods of communication, such as those described above, are needed for people who may have lost their hearing later in life and do not use sign language. Similarly, Braille is effective only for people who read Braille. Other methods are needed for people with vision disabilities who do not read Braille, such as providing accessible electronic text documents, forms, etc., that can be accessed by the person’s screen reader program.

Covered entities are also required to accept telephone calls placed through TRS and VRS, and staff who answer the telephone must treat relay calls just like other calls. The communications assistant will explain how the system works if necessary.

Remember, the purpose of the effective communication rules is to ensure that the person with a communication disability can receive information from, and convey information to, the covered entity.

---

## Companions

---

In many situations, covered entities communicate with someone other than the person who is receiving their goods or services. For example, school staff usually talk to a parent about a child’s progress; hospital staff often talk to a patient’s spouse, other relative, or friend about the patient’s condition or prognosis. The rules refer to such people as “companions” and require covered entities to provide effective communication for companions who have communication disabilities.

The term “companion” includes any family member, friend, or associate of a person seeking or receiving an entity’s goods or services who is an appropriate person with whom the entity should communicate.

---

## Use of Accompanying Adults or Children as Interpreters

---

Historically, many covered entities have expected a person who uses sign language to bring a family member or friend to interpret for him or her. These people often lacked the impartiality and specialized vocabulary needed to interpret effectively and accurately. It was particularly problematic to use people's children as interpreters.

The ADA places responsibility for providing effective communication, including the use of interpreters, directly on covered entities. They cannot require a person to bring someone to interpret for him or her. A covered entity can rely on a companion to interpret in only two situations.

(1) In an emergency involving an imminent threat to the safety or welfare of an individual or the public, an adult or minor child accompanying a person who uses sign language may be relied upon to interpret or facilitate communication only when a qualified interpreter is not available.

(2) In situations **not** involving an imminent threat, an adult accompanying someone who uses sign language may be relied upon to interpret or facilitate communication when a) the individual requests this, b) the accompanying adult agrees, and c) reliance on the accompanying adult is appropriate under the circumstances. This exception does **not** apply to minor children.

Even under exception (2), covered entities may **not** rely on an accompanying adult to interpret when there is reason to doubt the person's impartiality or effectiveness. For example:

- It would be inappropriate to rely on a companion to interpret who feels conflicted about communicating bad news to the person or has a personal stake in the outcome of a situation.
- When responding to a call alleging spousal abuse, police should never rely on one spouse to interpret for the other spouse.

---

### Who Decides Which Aid or Service Is Needed?

---

When choosing an aid or service, title II entities are **required** to give primary consideration to the choice of aid or service requested by the person who has a communication disability. The state or local government must honor the person's choice, unless it can demonstrate that another equally effective means of communication is available, or that the use of the means chosen would result in a fundamental alteration or in an undue burden (see limitations below). If the choice expressed by the person with a disability would result in an undue burden or a fundamental alteration, the public entity still has an obligation to provide an alternative aid or service that provides effective communication if one is available.

Title III entities are **encouraged** to consult with the person with a disability to discuss what aid or service is appropriate. The goal is to provide an aid or service that will be effective, given the nature of what is being communicated and the person's method of communicating.

**Covered entities may require reasonable advance notice from people requesting aids or services, based on the length of time needed to acquire the aid or service, but may not impose excessive advance notice requirements. "Walk-in" requests for aids and services must also be honored to the extent possible.**

---

### Limitations

---

Covered entities are required to provide aids and services unless doing so would result in an "undue burden," which is defined as significant difficulty or expense. If a particular aid or service would result in an undue burden, the entity must provide another effective aid or service, if possible, that would not result in an undue burden. Determining what constitutes an undue burden will vary from entity to entity and sometimes from one year to the next. The impact of changing economic conditions on the resources available to an entity may also be taken into consideration in making this determination.

**State and local governments:** in determining whether a particular aid or service would result in undue financial and administrative burdens, a title II entity should take into consideration the cost of the particular aid or service in light of all



resources available to fund the program, service, or activity and the effect on other expenses or operations. The decision that a particular aid or service would result in an undue burden must be made by a high level official, no lower than a Department head, and must include a written statement of the reasons for reaching that conclusion.

**Businesses and nonprofits:** in determining whether a particular aid or service would result in an undue burden, a title III entity should take into consideration the nature and cost of the aid or service relative to their size, overall financial resources, and overall expenses. In general, a business or nonprofit with greater resources is expected to do more to ensure effective communication than one with fewer resources. If the entity has a parent company, the administrative and financial relationship, as well as the size, resources, and expenses of the parent company, would also be considered.

In addition, covered entities are not required to provide any particular aid or service in those rare circumstances where it would fundamentally alter the nature of the goods or services they provide to the public. In the performing arts, for example, slowing down the action on stage in order to describe the action for patrons who are blind or have vision loss may fundamentally alter the nature of a play or dance performance.

---

## **Staff Training**

---

A critical and often overlooked component of ensuring success is comprehensive and ongoing staff training. Covered entities may have established good policies, but if front line staff are not aware of them or do not know how to implement them, problems can arise. Covered entities should teach staff about the ADA's requirements for communicating effectively with people who have communication disabilities. Many local disability organizations, including Centers for Independent Living, conduct ADA trainings in their communities. The Department's ADA Information Line can provide local contact information for these organizations.

**For more information about the ADA, please visit our website or call our toll-free number.**

**ADA Website**

**[www.ADA.gov](http://www.ADA.gov)**

To receive e-mail notifications when new ADA information is available,  
visit the ADA Website's home page and click the **link** near the top of the middle column.

**ADA Information Line**

800-514-0301 (Voice) and 800-514-0383 (TTY)

24 hours a day to order publications by mail.

M-W, F 9:30 a.m. – 5:30 p.m. , Th 12:30 p.m. – 5:30 p.m. (Eastern Time) to speak with an ADA Specialist.

All calls are confidential.

For persons with disabilities, this publication is available in alternate formats.

Duplication of this document is encouraged. January 2014

---

## **PDF Version of this Document**



ADA Requirements: Accessible Pools - Updated May 24, 2012



## Accessible Pools Means of Entry and Exit

The Department of Justice published revised final regulations implementing the Americans with Disabilities Act (ADA) for title II (State and local government services) and title III (public accommodations and commercial facilities) on September 15, 2010, in the Federal Register. These requirements, or rules, clarify and refine issues that have arisen over the past 20 years and contain new, and updated, requirements, including the 2010 Standards for Accessible Design ("2010 Standards").

### Overview

**Providing equal opportunity to people with disabilities is the fundamental principle of the Americans with Disabilities Act. This publication is designed to help title II and title III entities understand how new requirements for swimming pools, especially existing pools, apply to them.**

People with disabilities were, for too long, excluded from participating in many recreational activities, including swimming. The revised 2010 Standards change that. For the first time, the 2010 Standards set minimum requirements for making swimming pools, wading pools, and spas (pools) accessible. Newly constructed and altered pools must meet these requirements. Public entities and public accommodations also have obligations with respect to existing pools. State and local governments must make recreational programs and services, including swimming pool programs, accessible to people with disabilities. Public accommodations must bring existing pools into compliance with the 2010 Standards to the extent that it is readily achievable to do so.

The requirements for newly constructed and existing pools will ensure that, going forward, people with disabilities can enjoy the same activities—a community swim meet; private swim lessons; a hotel pool—at the same locations and with the same independence, ease, and convenience as everyone else.

The 2010 Standards establish two categories of pools: large pools with more than 300 linear feet of pool wall and smaller pools with less than 300 linear feet of wall. Large pools must have two accessible means of entry, with at least one being a pool lift or sloped entry; smaller pools are only required to have one accessible means of entry, provided that it is either a pool lift or a sloped entry.

There are a limited number of exceptions to the requirements. One applies to multiple spas provided in a cluster. A second applies to wave pools, lazy rivers, sand bottom pools, and other pools that have only one point of entry. For more information on the specific

requirements and exceptions, see sections [242](#) and [1009](#) of the 2010 Standards.

## Existing Pools

### Title II Program Accessibility

Individuals with disabilities cannot be excluded from or denied participation in State and local government programs, services, or activities because a facility is inaccessible or unusable. This means that all programs, services, and activities, when viewed in their entirety, must be accessible to individuals with disabilities unless doing so results in a fundamental alteration in the nature of the program or in an undue financial and administrative burden. This requirement is known as "program accessibility."

Program accessibility applies to all pool-related programs, services, and activities (swimming programs). Program accessibility does not typically require that every pool be made accessible. However, if a public entity has only one existing pool, it must take steps to ensure that its swimming program at that pool is accessible.

A public entity determines which method it will use for meeting its program accessibility obligations. When structural changes are made to existing pools, including installation of a fixed pool lift, the changes must comply with the 2010 Standards. If a public entity chooses to acquire equipment (e.g., a portable lift) to provide program accessibility, the entity should select equipment that includes features required by the 2010 Standards, including independent operation by individuals with disabilities. Sharing accessible equipment between pools is not permitted, unless it would result in undue burdens to provide equipment at each one. Accessible pool features must be available whenever the facility is open to the public. When choosing to purchase equipment or to make structural changes, the public entity should factor in staff and financial resources required to maintain program accessibility.

Over time, a public entity will need to reassess its compliance with program accessibility, and it may become necessary to acquire new accessible equipment or make structural modifications. For more information about program accessibility, see [the title II regulations at Section 35.150](#).

#### **To determine which pools must be made accessible, public entities should consider the following factors:**

- How to provide swimming programs in the most integrated setting appropriate;
- The ways in which people participate in the programs (e.g., individually, in families, in youth groups);
- Locations where the programs are offered;
- What programs are offered at each pool and to which constituencies (e.g., family swims, children's swimming lessons, older adult exercise classes, high school swim meets);
- Which pools are accessible and to what extent; and
- Level of dispersion of the accessible locations and convenience to reach them (e.g., one pool in each quadrant of the town, all on accessible mass transit).

### Title III Readily Achievable Barrier Removal

Title III of the ADA requires that places of public accommodation (e.g., hotels, resorts, swim clubs, and sites of events open to the public) remove physical barriers in existing pools to the extent that it is readily achievable to do so (i.e., easily accomplishable and able to be carried out without much difficulty or expense).

Determining what is readily achievable will vary from business to business and sometimes from one year to the next. Changing economic conditions can be taken into consideration in determining what is readily achievable.

For an existing pool, removing barriers may involve installation of a fixed pool lift with independent operation by the user or

other accessible means of entry that complies with the 2010 Standards to the extent that it is readily achievable to do so. If installation of a fixed lift is not readily achievable, the public accommodation may then consider alternatives such as use of a portable pool lift that complies with the 2010 Standards. It is important to note that the barrier removal obligation is a continuing one, and it is expected that a business will take steps to improve accessibility over time. When selecting equipment, the public accommodation should factor in the staff and financial resources needed to keep the pool equipment available and in working condition at poolside. For more information about barrier removal, see the title III regulations at [Section 36.304](#).

If you have purchased a non-fixed lift before March 15<sup>th</sup> that otherwise complies with the requirements in the 2010 Standards for pool lifts (such as seat size, etc.), you may use it, as long as you keep it in position for use at the pool and operational during all times that the pool is open to guests. Because of a misunderstanding by some pool owners regarding whether the use of portable pool lifts would comply with barrier removal obligations, the Department, as a matter of prosecutorial discretion, will not enforce the fixed elements of the 2010 Standards against those owners or operators of existing pools who purchased portable lifts prior to March 15, 2012 and who keep the portable lifts in position for use at the pool and operational during all times that the pool is open to guests so long as those lifts otherwise comply with the requirements of the 2010 Standards. Generally, lifts purchased after March 15, 2012 must be fixed if it is readily achievable to do so.

**To determine which pools must be made accessible, public accommodations should consider the following factors:**

- The nature and cost of the action;
- Overall resources of the site or sites involved;
- The geographic separateness and relationship of the site(s) to any parent corporation or entity;
- The overall resources of any parent corporation or entity, if applicable; and
- The type of operation or operations of any parent corporation or entity, if applicable.

## New Construction and Alterations

### **New Construction**

The 2010 Standards, which set requirements for fixed elements and spaces, require that all new pool facilities built by State and local governments, public accommodations, and commercial facilities must be accessible to and usable by persons with disabilities.

### **Alterations**

A physical change to a swimming pool which affects or could affect the usability of the pool is considered to be an alteration. When pools are altered, the alterations must comply with the 2010 Standards, to the maximum extent feasible. Changes to the mechanical and electrical systems, such as filtration and chlorination systems, are not alterations. Entities must ensure that an alteration does not decrease accessibility below the requirements for new construction. For example, if a hotel installs a fixed pool lift powered by water pressure, it must ensure that the hose connecting to the lift does not create a barrier across the accessible route to the pool.

## Compliance Dates

### **On or after March 15, 2012**

All newly constructed or altered facilities of public entities and public accommodations, including pools, must comply with the 2010 Standards.

### **On or after March 15, 2012**

All existing facilities of public entities and public accommodations, **except** pools, must comply with the 2010 Standards to the extent required under title II program accessibility or title III readily achievable barrier removal requirements.

### **On or after January 31, 2013**

Subject to other provisions of this guidance, all existing pools of public entities and public accommodations must comply with the 2010 Standards to the extent required under title II program accessibility or title III readily achievable barrier removal requirements.

For more information on effective dates, see the Department's publication called *ADA 2010 Revised Requirements: Effective Date and Compliance Date* and the *2010 Standards for Accessible Design*.

## **Maintenance of Accessible Features**

Accessible pool features must be maintained in operable, working condition so that persons with disabilities have access to the pool whenever the pool is open to others. For example, a portable pool lift may be stored when the pool is closed but it must be at poolside and fully operational during all open pool hours.

An entity should recognize that certain types of equipment may require more staff support and maintenance than others (e.g. ensuring there are enough batteries for a pool lift to maintain a continued charge during pool hours). Entities should plan for these issues and modify operational policies as needed to provide accessible means of entry while the pool is open.

## **Staff Training**

Ongoing staff training is essential to ensure that accessible equipment (particularly pool lifts) and pool facilities are available whenever a pool is open. Staff training should include instruction on what accessible features are available, how to operate and maintain them, and any necessary safety considerations.

## **Tax Credits and Deductions**

Title III entities may be able to take advantage of federal tax credits for small businesses (Internal Revenue Code section 44) or deductions (Internal Revenue Code section 190) for barrier removal costs or alterations to improve accessibility regardless of the size of the business. See the IRS website [www.irs.gov](http://www.irs.gov) for more information.

**For more information  
about the ADA,  
please visit our website  
or call our toll-free number.**

**ADA Website: [www.ADA.gov](http://www.ADA.gov)**

### **ADA Information Line**

800-514-0301 (Voice) and  
800-514-0383 (TTY)  
24 hours a day to order  
publications by mail.

M-W, F 9:30 a.m. – 5:30 p.m.,  
Th 12:30 p.m. – 5:30 p.m. (Eastern Time)  
to speak with an ADA Specialist.  
All calls are confidential.

For persons with disabilities,  
this publication  
is available in alternate formats.

**Duplication of this document  
is encouraged.**

May 2012

ADA Requirements: Accessible Pools - Updated May 24, 2012

---

**[PDF Version of this Document](#)**

last updated: May 24, 2012



# A Planning Guide for Making Temporary Events Accessible to People with Disabilities



**2015**

---

# Table of Contents

Introduction .....	1
CHAPTER One – Disability Awareness and Nondiscrimination .....	2
OVERVIEW OF THE AMERICANS WITH DISABILITIES ACT (ADA).....	2
Definition of Disability under the ADA.....	2
Structure of the ADA .....	4
OTHER ACCESSIBILITY LAWS AND CODES.....	6
CHAPTER Two – Planning .....	7
SITE SELECTION.....	8
GET STARTED EARLY .....	9
Modifications to a Site—Removing Barriers.....	9
Communication Access.....	11
Vendors .....	12
Preparing Staff and Volunteers .....	12
Accessible Performance Areas.....	12
PUBLICITY OF THE EVENT .....	12
CHAPTER Three – Getting to the Event Site .....	16
GENERAL CONSIDERATIONS .....	16
Signage .....	16
Curb Ramps .....	16
Sidewalks .....	17
Barricades.....	17
PARKING .....	18
DROP-OFF AREAS.....	24
CHAPTER Four – Participating in the Event .....	26
GETTING AROUND .....	26
Space Requirements for Wheelchairs .....	26
Accessible Route.....	27
Entrances.....	29
Ground and Floor Surfaces .....	31
Temporary Ramps & Lifts .....	33
Elevators.....	35
Doors .....	35
Eliminating Hazardous Protruding and Overhanging Objects .....	36
Tents, Tarps, and Similar Temporary Structures .....	36
Information and Ticketing .....	36
Signage .....	37



TAKING PART IN EVENT .....	38
Exhibits and Displays .....	38
Participating in Activities .....	40
Assembly Areas.....	42
Eliminating Communications Barriers .....	43
Games and Amusement Rides.....	46
Concessions .....	47
CHAPTER Five – Service and Support Facilities .....	48
TOILET FACILITIES .....	48
AVAILABILITY OF DRINKING WATER .....	51
SHELTER.....	52
CHAPTER Six – Resources.....	53
ADA NATIONAL NETWORK REGIONAL CENTERS .....	53
ASSISTIVE TECHNOLOGY RESOURCES.....	55
FEDERAL AGENCIES .....	56
STATE AGENCIES.....	57
CENTERS FOR INDEPENDENT LIVING.....	57

## Acknowledgments

The content for this planning guide was adapted from the *Accessible Temporary Event, A Planning Guide*, published in 1998 by the Center for Universal Design at North Carolina State University in collaboration with the Southeast ADA Center (formally named the Southeast DBTAC). The authors of this original guide generously permitted substantial revisions to content to ensure accuracy of content and improve readability. Authors and editors of original guide included Ronald L Mace and Rex J. Pace, Leslie C. Young, and Karen Olander.

The development of the current version was facilitated by the ADA Knowledge Translation Center (ADAKTC) at the University of Washington, specifically by;

    Editors: Cynthia Salzman and Rebecca Matter

    Editing assistant: Aditya Ganapathiraju

    Graphic designer: Greg Owen

Expert reviewers from the ADA National Network who ensured accuracy of content include Troy Balthazor, Peter Berg, Jan Garrett, Karen Goss, and Michael Richardson. A special thanks to Nancy Horton for her careful review and editing on multiple sections.

---

# Introduction

Street festivals, craft fairs, music events, sporting events and home shows are but a few of the many temporary events that take place every day in communities both large and small throughout the nation. Temporary events celebrate and support a “sense of community” and must encourage participation by all people.

This guide provides information to assist planners, managers, operators and building owners in making temporary events accessible to people with disabilities.

This guide acquaints the reader with:

- The value of making temporary events accessible.
- An overview of the law.
- Planning strategies to help prevent discrimination.
- Typical barriers encountered by people with disabilities and solutions for removal.
- Methods of locating and coordinating available resources to achieve accessibility.

This guide addresses most questions about how to host an accessible temporary event. However, if you have additional questions, please call your regional ADA Center for more information at **1-800-949-4232**.

*The Americans with Disabilities Act (ADA) is part of our larger civil rights tradition which recognizes and celebrates diversity and strives to include all members of our society. It is in this spirit that accessibility should be embraced.*

---

# CHAPTER One – Disability Awareness and Nondiscrimination

People with disabilities have the same hopes and dreams as people without disabilities. They want to access their communities and attend events with their friends and families. It is estimated that more than 21 percent of Americans aged 15 and over and 50 percent of Americans 65 years and older presently have some type of disability (Census, 2010). At some point in their lifetime, 70 percent of all Americans will have either a temporary or permanent disability.

Not until the passage of the Americans with Disabilities Act (ADA) in 1990 did people with disabilities make a significant step toward being able to move and function as freely in society as people without disabilities.

## OVERVIEW OF THE AMERICANS WITH DISABILITIES ACT (ADA)

The ADA is a federal civil rights law that prohibits discrimination against people with disabilities in the areas of employment, transportation, access to private and state and local government sites and telecommunications. Much of the ADA's spirit and language comes from earlier nondiscrimination legislation regarding race, color, sex, national origin, age and religion.

### Definition of Disability under the ADA

The ADA defines a person with a disability as:

- A person who has a physical or mental impairment that substantially limits one or more major life activities. Examples of major life activities include caring for one's self, performing manual tasks, walking, seeing, hearing, speaking, learning, and working,
- A person with a record of an impairment even if he or she does not currently have a disability and,
- A person who does not have a disability, but is regarded by others as having a disability. An example may be a person who has severe facial scarring.

### Types of Disabilities

There are hundreds of different types of disabilities. While one person may have multiple disabilities, another may have a single disability with symptoms that fluctuate. There are some disabilities that are less obvious, such as diseases of the heart or lungs, neurological diseases, or arthritis that may reduce physical stamina, decrease coordination or cause pain.

---

Temporary conditions that cause disability for a short time — such as broken bones, illness, trauma or surgery — are not considered disabilities as defined under the ADA unless they are expected to continue over a long period of time.

Most architectural design standards are based on the needs of people defined by one of the following four general categories:

### 1. Mobility Disabilities

- a. **Wheelchair Users** - Some people with severe mobility disabilities use power-driven or manually operated wheelchairs or a three- and four-wheeled cart or scooter to maneuver through their environment. People who use wheelchairs encounter some of the most obvious access problems, including maneuvering through narrow spaces, going up or down steep paths, moving over rough or uneven surfaces, making use of toilet and bathing facilities, reaching and seeing items placed at conventional heights, and negotiating steps or abrupt changes in level.
- b. **Ambulatory Mobility Disabilities** - This category includes people who walk with difficulty or who have a disability that affects gait or balance. People who use crutches, canes, walkers, braces, or artificial limbs to assist them in walking are also included in this category. Activities that may be difficult for people with mobility disabilities include walking, climbing steps or slopes, standing for extended periods of time, reaching and fine finger manipulation. Both people who use wheelchairs and those who use other types of mobility aids sometimes use service animals for assistance. For example, a specially trained service dog may be used to retrieve items or even pull a wheelchair.

### 2. Visual Disabilities

This category includes people with partial vision or total vision loss. Some people with a visual disability can distinguish between light and dark, sharply contrasting colors, or large print, but may not be able to read small print, negotiate dimly lit spaces, or tolerate high glare. Many people who are blind generally depend upon their other senses to perceive their environment and communicate with others, though this does not mean their other senses are much more acute. Many use a cane or have a guide animal to facilitate moving about. Some problems experienced by people with visual impairments may include orientation, receiving written or graphic information, using controls that are not adequately labeled, and avoiding hazardous protruding objects which they cannot detect.

### 3. Hearing Disabilities

People in this category use a variety of methods to compensate for their inability to hear sound. Those with partial hearing may depend on hearing aids or lip reading. Some people who are totally deaf also use speech-reading but must be able to clearly see the face of the individual speaking. Others use a standard means of communication called American Sign Language. People can learn sign language to become qualified

---

interpreters. Some people with hearing disabilities may use service animals to alert them to sounds. Problems for people with hearing impairments include communicating with many hearing people and using equipment that is exclusively auditory, such as telephones and fire alarms. Lack of sign language interpreters and inadequately trained interpreters also can be a problem.

#### **4. Cognitive Disabilities and Other Hidden Disabilities**

There are many other disabling conditions which are not apparent from an individual's outward appearance. These usually involve cognitive and/or learning abilities and may affect understanding, communication, or behavior. People with these types of disabilities may have difficulty navigating facilities, particularly where the signage system is unclear or complicated. People who have seizure disorders may be sensitive to environmental features, such as lighting, which can activate seizures.

A hidden condition gaining greater awareness is a condition known as multiple chemical sensitivity. People with this condition experience a physical reaction that generally affects breathing when they come in contact with a chemical or combination of chemicals that may be present in many buildings and consumer products. These can include items such as lawn pesticides and herbicides, room deodorants, printing inks, and even colognes or perfumes. Reactions can range from mild to life threatening.

### **Structure of the ADA**

The ADA is comprised of five sections or "titles" that address discrimination in different areas of society:

- Title I covers private sector employment.
- Title II covers state and local government programs, activities, services, and employment.
- Title III covers private businesses and nonprofit service organizations (public accommodations and commercial facilities).
- Title IV covers telecommunications.
- Title V covers certain miscellaneous legal and procedural aspects of the law.

Titles I, II, and III are the most relevant to someone who is planning a temporary event

### **Non-Discrimination Requirements**

The ADA states that people with disabilities must be able to obtain or enjoy "the same goods, services, facilities, privileges, advantages, or accommodations" that are provided to other members of the public. As such, there are some general requirements in place to ensure equal opportunity for people with disabilities. The business, government agencies, and other public and private organizations and facilities covered by the ADA are referred to as "entities."

Under the ADA, entities may not:

- Discriminate on the basis of disability in areas of programs, services, or activities.
- Ask unnecessary questions about a person's disability.

- 
- Deny benefits or services to people with disabilities.
  - Impose eligibility requirements that exclude or segregate individuals with disabilities.
  - Impose extra charges for people with disabilities to cover costs that are necessary to ensure nondiscriminatory treatment, such as removing barriers or providing qualified interpreters.

### **Modifying Policies and Procedures**

Event organizers may need to modify their policies and procedures to make sure they do not discriminate against persons with disabilities. For example, food vendors may have to leave their booths briefly to assist someone with limited hand dexterity in reaching their money.

Organizers also may need to modify their policies regarding service animals. A service animal is a dog (or, in some cases, a miniature horse) that assists a person with a disability in performing one or more tasks related to their disability. Many temporary events have a “no pets” policy. However, a service animal is not a pet and must be allowed into any part of the event that its handler is allowed to attend. Event staff may only ask two questions of a service animal handler: 1) is this a service animal that is needed for the person’s disability?; and 2) what task(s) is the animal trained to perform? Service animals must be housebroken and under the control of their handler at all times.

### **Effective Communication**

Event organizers must provide auxiliary aids and services where necessary to ensure effective communication.

“Effective Communication” means that whatever is written or spoken must be as clear and understandable to people with disabilities as it is for people who do not have disabilities.

Some examples of auxiliary aids and services are: large print material, Braille material, assistive listening systems, qualified sign language interpreters, telecommunication devices for the deaf (TDD, also called TTY for teletypewriter), open/closed captioning, handwritten notes, and audio tapes.

Remember that the person with a disability is the best person to ask what type of service or aid will be most effective for them.

### **Accessible Design**

The ADA requires all buildings and facilities that are open to the public to be accessible. This includes temporary structures that are extensively used by or are essential for the public use at an event.

The Standards do not provide direct solutions to all of the various barriers that may be

---

encountered at a temporary event, but instead give basic guidelines for resolving most problems. The design recommendations and solutions presented in this guide are based on the 2010 ADA Standards.

## **OTHER ACCESSIBILITY LAWS AND CODES**

This publication primarily focuses on accessibility under the ADA, but other disability legislation also could potentially affect temporary events.

**The Architectural Barriers Act (1968)** - This Act stipulates that most buildings, other than privately-owned residential facilities, constructed by, on behalf of, or leased by the United States, or buildings financed in whole or in part by the United States, must be physically accessible for people with disabilities.

**Section 504 of the Rehabilitation Act (1973)** - Under this Section, no qualified individual with a disability may be discriminated against in any program or activity receiving federal financial assistance.

**State and Local Codes** – Many states have developed their own building codes for accessibility. Organizers need to know about both federal law and state/local codes that may apply to their events.

---

# CHAPTER Two – Planning

People with disabilities must be able to obtain or enjoy the same goods, activities, services, and benefits that are available to other members of the public. At a temporary event participants with disabilities must be able to:

- Obtain information and directions prior to the event.
- Arrive at the site in the same ways as others can (e.g. via private automobile, taxi, public transportation, event shuttles).
- Find and use accessible parking.
- Get from accessible parking to entrances.
- Obtain additional information and directions on site.
- Move around the site as needed.
- Attend performances, participate in activities, and enter exhibits.
- Experience and enjoy activities, even if the participant’s disability affects their ability to communicate.
- Select and purchase items at concessions.
- Use public toilet rooms, telephones, water fountains, shelters, first aid stations, and other common amenities.

## Plan Early and Review Often

Planning for accessibility from the beginning improves the chances of creating an event that is enjoyable for all participants. Efforts to provide access after critical decisions have been made, such as selecting a site, may result in “add-on” solutions that may be more costly or less effective than necessary. Organizers should review the entire process of producing the event often to ensure that accessibility is provided and maintained.

## Accessibility Coordinator

An effective strategy for managing accessibility efforts is to designate an “accessibility coordinator” to oversee all phases of the event, from planning to completion. This role is especially important for larger events where many diverse elements must be managed.

## Resources for Planning

**Advisors.** Invite participation of individuals with various disabilities early on to help with site selection and other concerns.

For large events, you may want to establish an advisory committee representing a range of disabilities and experience. Since access issues often have an architectural component, include people who also have design experience.

**Disability Organizations.** Local and national disability groups and organizations are excellent resources for information and advice and can help you find services such as sign language interpreters or renting equipment such as assistive listening systems or portable ramps. For more information on disability groups and organizations, see Chapter 6: “Resources”.



**Architectural Accessibility Consultants.** Accessibility consultants are a source of advice and information, particularly for solutions to specific architectural barriers. If funds are available, hire a firm or an individual with both accessibility and architectural design experience.

## SITE SELECTION

Site selection may have the greatest overall impact on accessibility to an event. Inaccessible architectural features may be among the most difficult barriers to remove.

Many facilities were constructed before the passage of the ADA, and perhaps even before state or local laws required accessibility. Even partially accessible sites can be improved with planning. If more than one site is available, accessibility should be a primary consideration in making the final choice.

### The Importance of an Accessible Route

An accessible route is critical to the successful use of a site. A single continuous accessible pedestrian path should be wide, smooth, as level as possible, and without low or overhanging hazards or obstructions. Accessible routes can include ramps but not stairs (see Figure 1).

**Figure 1**

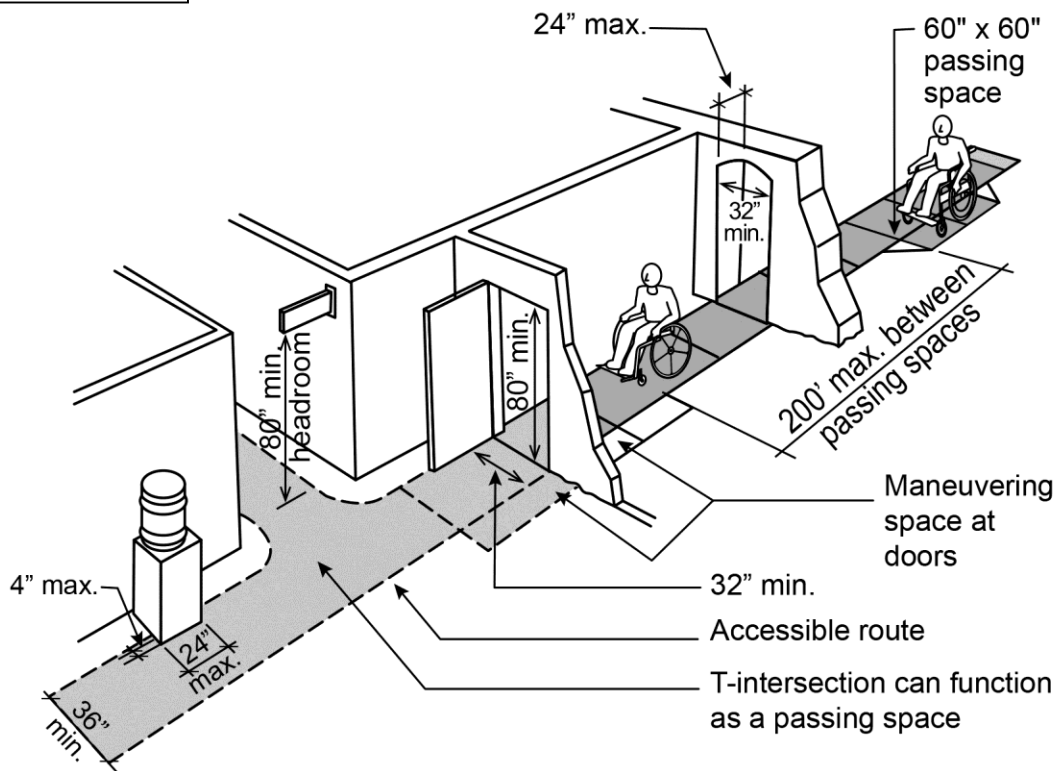

**Basic Features of an Accessible Route**

---

A complete review of the site is necessary to determine if people with disabilities will be able to move around the site, get to facilities, and participate in activities. Walk the site and identify the accessible (or most accessible) routes. People with disabilities should be able to use the same route as everyone else whenever possible, and should not have to travel unusually long distances to reach a destination.

### **Evaluating the Site**

Newer sites usually are more accessible than older ones. Many facility owners and operators may not have the experience or knowledge to determine the level of accessibility on their sites. If they have never received any complaints, they may mistakenly assume that no problems exist. Inspect all areas of the site carefully to make an accurate assessment of its level of accessibility.

### **Use a Checklist**

Assess sites, identify barriers, and determine what kinds of modifications may be needed by using the checklist at <http://adachecklist.org/checklist.html>.

## **GET STARTED EARLY**

Event organizers generally have more direct control over the accessibility of the event's activities than over the site. If site modifications are required, they may take some time to accomplish, so try to tackle these issues early. Make marketing and promotional materials available in a variety of formats. Design and set up temporary structures such as tents, stages, and portable toilets, with access in mind.

### **Modifications to a Site—Removing Barriers**

There are both financial and legal incentives for owners to remove barriers. As the number of people with disabilities increases, particularly among the expanding population of older Americans, more accessible sites are in demand.

Additionally, facility owners and managers must meet the ADA's legal requirements for access and should have already taken action to remove barriers. All privately-owned businesses that serve as places of public accommodation (such as hotels, restaurants, theaters, museums, auditoriums, convention centers, shopping centers, parks, zoos, or amusement parks) are covered by Title III of the ADA and are expected to remove barriers when it is "readily achievable" —i.e., when it can be carried out without much difficulty or expense.

What is "readily achievable" is based on an entity's size, financial resources, and the existing site conditions. What might be readily achievable for a large multi-national investment company may be very different from what is readily achievable for a community group sponsoring a one-day craft or antique show.

Ways to remove barriers:

- 
- Install ramps.
  - Make curb cuts in sidewalks and at entrances.
  - Reposition shelves.
  - Rearrange tables, chairs, vending machines, display racks, and other furniture.
  - Add raised markings on elevator control buttons.
  - Install flashing alarm lights.
  - Widen doors\install offset hinges to widen doorways.
  - Eliminate a turnstile or provide an alternative accessible path.
  - Install accessible door hardware.
  - Install grab bars in toilet stalls.
  - Rearrange toilet partitions to increase maneuvering space.
  - Insulate lavatory pipes under sinks to prevent burns.
  - Install a raised toilet seat.
  - Install a full-length bathroom mirror.
  - Reposition the paper towel dispenser in a bathroom.
  - Create designated accessible parking spaces.
  - Install an accessible paper cup dispenser at an existing inaccessible water fountain.
  - Remove carpeting that makes maneuvering wheelchairs difficult (i.e. high pile, low density carpeting).

Event organizers can remind owners and operators of facilities that modifications needed for a temporary event can help them meet their overall ADA obligations.

### **Removing Barriers—Title II vs. Title III**

Under Title II state or local governments (public entities) must make their programs accessible. Sometimes programs and services can be relocated to accessible sites or services can be delivered in alternate ways, but often architectural modifications must be made to existing facilities when there is no other feasible way to make the program accessible.

In contrast, under Title III places of public accommodation (private businesses and nonprofit service organizations) must remove barriers if it is “readily achievable,” without regard to whether their services can be made accessible through other methods. (From the Department of Justice Title II Technical Assistance Manual (1993) and Supplements, Item II-5.2000.)

### **Temporary vs. Permanent Modifications**

Entities must make permanent architectural modifications to ensure program access unless this would cause an “undue burden,” i.e., if the modifications would be excessively difficult or expensive. After identifying barriers, organizers can negotiate with the owners/managers of the facility to encourage them to improve access. It may be possible to tie the completion of these changes to a rental contract agreement. A more accessible site may very well give the facility operators a competitive edge over those

---

with less accessible facilities.

When permanent changes to a site cannot be made and the entire event or specific activities of the event cannot be relocated, organizers should consider temporary modifications (see Chapter 4: “Participating in the Event”).

### **Modifying Policies and Procedures**

Sometimes policies or procedures may reduce access as much as physical barriers. However, modifications to policies and procedures, or the addition of services to accommodate people with disabilities, are not required if they would cause a “fundamental alteration” in the essential nature of an event or a specific activity.

### **Communication Access**

People who are blind or have low vision may need aids or services ranging from materials in large print, Braille, or audio format, to staff reading information aloud, describing visual elements (such as images or graphics in a slide show), giving directions, or providing guidance to help locate facilities or activities.

People who are deaf or hard of hearing may need written materials, captioned media, assistive listening devices, or sign language interpreter services.

The type of assistance needed will depend on a number of factors, including the individual’s needs and preferences, as well as the nature of the event or activity. For example, where brief, casual information is exchanged, such as at a booth selling a local artist’s photographs, use of pencil and paper is probably sufficient to communicate with a person who is deaf. However, a sign language interpreter or a real-time captioning display may be needed for the same person to attend a presentation or performance.

Interpreters should be appropriately qualified. Types of interpreters and skill levels vary, and some specialize in certain types of situations, such as interpreting for musical or dramatic performances.

Some communication devices or services should be available “by default” (such as assistive listening devices in a stadium). Other communication services may require more preparations and resources (such as sign language interpreters or real-time captioning services). If advanced registration is required, event organizers may want to provide certain communication services by request. Promotional and registration materials should include contact information and a reasonable deadline for participants to request such services. For other types of events, particularly large, open events where hundreds or thousands of participants can be expected to show up, organizers may actually find it easier to simply provide communication access services rather than deal with the logistics of requests and deadlines. Promotional materials should advertise any aids or services that will be available (for example, “Sign language interpreters will be available for the awards ceremony”).

---

## Vendors

Work with vendors to ensure that people with disabilities will have comparable access to food, drinks, merchandise, or services offered. While concession carts may not be easily modified, vendors should offer additional assistance so people with disabilities can obtain goods and services. For example, a vendor may need to take items from an inaccessible area to an interested individual in order to allow the individual to evaluate and select merchandise or to participate in an activity offered. (For more detail, see Chapter 4: “Participating in the Event.”)

## Preparing Staff and Volunteers

All staff and volunteers should have a basic awareness of and sensitivity to disability issues. Make it clear to staff and volunteers that people with disabilities expect to be treated like all other event participants. Advise staff as follows:

- View an individual in terms of the whole person and not just the disability.
- Avoid being anxious or overly protective; people will let you know what they need.
- Some people will need extra time to move, speak, perform a task, or participate in an activity. The behavior of some people with developmental or cognitive disabilities may be unsettling to people unfamiliar with these disabilities. There is no need for fear and, as with others, respect and patience is expected. In other words, provide good customer service to everyone.

Make sure that staff and volunteers know the location or availability of accessible features, such as accessible toilet rooms, TTYs, or ramps.

## Accessible Performance Areas

Speakers or performers with disabilities may need modifications to stages or performing areas. High stages are more difficult to make accessible. It is generally not acceptable or safe to carry a person with a disability up steps. If the stage is very high, portable lifts may be rented. Where an existing ramp is steeper than specified in the ADA Standards and cannot be modified, people traversing the ramp should be assisted by several competent trained individuals to prevent falls and mishaps. Presenters with hearing, speech, or vision disabilities usually can help you decide if aids or services are needed to get their message across or interact with the audience.

## PUBLICITY OF THE EVENT

Many people with disabilities will assume that temporary events will not be accessible. It is important to include statements about access on all publicity and informational material. Statements affirming your commitment to nondiscrimination and accessibility are important. It also may be necessary to provide information on the location of accessible features, such as accessible parking or toilet facilities, or where to obtain other aids or services, such as materials in accessible formats or assistive listening devices.

## Accessibility Symbols

Publicity materials should include appropriate symbols of accessibility to indicate various features, aids, or services (Figure 2).

The most recognized symbol is that of the individual seated in a wheelchair. However, it should be used appropriately to designate spaces or elements that are designed to be accessible to individuals with mobility disabilities. Other accessibility symbols, such as the International Symbol of Access for Hearing Loss, to indicate the availability of assistive listening devices, or the Symbol for Sign Language Interpretation can be included as appropriate on brochures, handouts, and publicity pieces.



Figure 2

## Publicity Options

Not all people receive information the same way. Print materials are generally usable for the person who can see and read, but some people must rely on hearing, touch, pictograms and images, or other methods of getting information. Use a variety of publicity formats, methods, and media options to ensure that information reaches the widest possible audience.

Local disability groups and organizations can help you publicize accessible activities, programs, or services offered at your event. These groups can be effective in getting the word out to members of the community who may not be reached by traditional media.

**Broadcast Media.** Television and radio may reach many people with disabilities in ways print media cannot. Broadcast media may be beyond the scope or budget of many events; however, depending upon the nature of the event, there may be opportunities for public service announcements, cable access channels, or donated airtime.

Although radio can be used to communicate to large numbers of people, it is not effective for people with hearing disabilities. Television can be an ideal way to publicize events since it has both audio and visual features. Television announcements that can be heard should be accompanied by on-screen text or captions that can be seen.

**Internet-Based Communication.** Websites and social media (Facebook, Twitter, etc.) are excellent and cost-effective ways to get the word out about events. Again, care should be taken to ensure that images or audible information is accompanied by text to make it accessible to individuals with hearing or vision disabilities.

**Print Media.** Flyers, brochures, and newspaper or magazine advertisements should be presented in typefaces that are large, high contrast, and easy to read. This increases legibility for people with limited vision and makes it easier for everyone.

---

## Usable Type for Printed Information

Most temporary events rely heavily on printed information, both as part of the advertising campaign and during the event itself. Make sure to consider the needs of people with disabilities, especially those who have vision or cognitive disabilities, when designing newspaper ads, fliers, programs, schedules, maps, and exhibit descriptions. While the ADA does not specifically address the design of printed materials, the following information can help you design user-friendly printed materials. Note: “Printed material” used here does not include permanent and temporary signs, which are addressed under “Signage” on page 37.

Printed materials should have text that is simple and contrasts with the background. When graphics are included, they should be clear and not overprinted onto type.

### Tips for content

- Use clear, non-technical English in the active voice.
- Use short sentences, preferably with fewer than 25 words. If possible, keep each sentence to one thought.
- Use bulleted or numbered lists for instructions, usually limited to three or four items per list.

### Tips for type design

- Use sans serif (Helvetica, Arial, Calibri and Futura) or simple serif (New Century Schoolbook and Palatino) type faces. Limit the number of typeface varieties to two or three.
- Use bold face type for single-page fliers that are posted, for example, on a bulletin board.
- Use at least 16-point type size when possible. Existing documents may be enlarged on a photocopier if clear images can be produced.
- Use line spacing of one and one-half or double. In typesetter’s language, this means that line spacing should be about 20 percent larger than the type size. For example, if the type size is 14 points, line space should be at least 17 to 18 points.
- Use lower case letters with initial capitals. Do not use all capitals.
- Avoid underlining.
- Justify text on left side only. Type that is justified both left and right hinders legibility because it creates awkward spaces between words.
- If narrow columns of text are used, provide at least an inch of white space between columns.
- Choose text/background color combinations that contrast with each other. Avoid, for example, combinations such as yellow on gray. In dimly lighted spaces, white type on a black background is slightly more legible than black type on a white background. But the type size under these circumstances must be at least 12 points or larger. Dark type on a light background works marginally better than light on dark for large type such as headlines.
- Use opaque, non-glossy colors and materials for the background and the text.

---

## **Responding to Accessibility Inquiries**

Be prepared to respond to questions regarding accessibility, especially if publicity cannot provide complete details. If the event is large and there are a variety of accessibility issues, it may be best to have a designated, knowledgeable person respond to questions.

The capacity to communicate over the telephone with people who have hearing or speech disabilities is very important. Many people with these types of disabilities use telecommunication devices or methods, including texting, TTYs (small “teletypewriters” that connect to standard telephones and facilitate text-based communication), or Telecommunications Relay Service (TRS), which may be text-based or sign language based (Video Relay Service, or VRS).

Telecommunications Relay Services are provided through the telephone system, and calls are facilitated by “communications assistants” (CAs) who act as go-betweens for the parties. The CA is connected to the individual with a disability, usually either by TTY or web-based technologies (for sign language), and to the other party with standard telephone equipment. The CA simply relays the conversation back and forth. The service is always available, free to use, and does not require businesses or agencies to have any specialized equipment.



---

# CHAPTER Three – Getting to the Event Site

Participants arrive at an event singly, accompanied by friends/family, or in groups. They use personal cars and vans, public buses, taxis, or other modes of transit such as rail. All visitors, including people with disabilities, arrive at the site using these modes of transportation and must be able to move about with safety and ease.

The design and location of accessible parking spaces, transit stops, drop-off areas, and public sidewalks are critical. Additionally, buildings and site amenities that are part of the event experience must be connected to these areas by an accessible route, i.e., a path that is wide, smooth, and as level as possible without hazards or obstructions.

## GENERAL CONSIDERATIONS

Permanent changes that conform to the ADA Standards are better than temporary modifications. Depending on unique site conditions and the particular mode of transportation, these modifications may vary significantly. Adequate signage, level changes at curbs, and the condition of traveling surfaces will always be concerns. When considering the extent and nature of the modifications it is important to consider what would be readily achievable for private businesses and nonprofit service organizations or would be part of program access for a state or local government.

### Signage

Signage is needed to direct the public to the location of accessible parking spaces, passenger drop-off points and transit stops and accessible entrances and gates. Signs should include the international symbol of accessibility, use easy-to-read typefaces, and be large enough to be read from a distance (see Signage on page 37).

### Curb Ramps

Curb ramps, or “cuts,” are used to overcome level changes along streets and parking lots. A curb ramp designed to meet the specifications of the Standards must have slopes no steeper than 1 in 12 (1 inch of rise for every 12 inches of run). They may have flared sides that slope as steeply as 1 in 10 if the flare is not directly in the pedestrian path of travel.

Numerous manufacturers fabricate portable ramps. Some are specially designed to bridge curbs and are appropriate for use at a temporary event. The ramp must be securely attached so it does not move or shift during use (Figure 3). Temporary wood curb ramps also can be fabricated as needed (Figure 4).

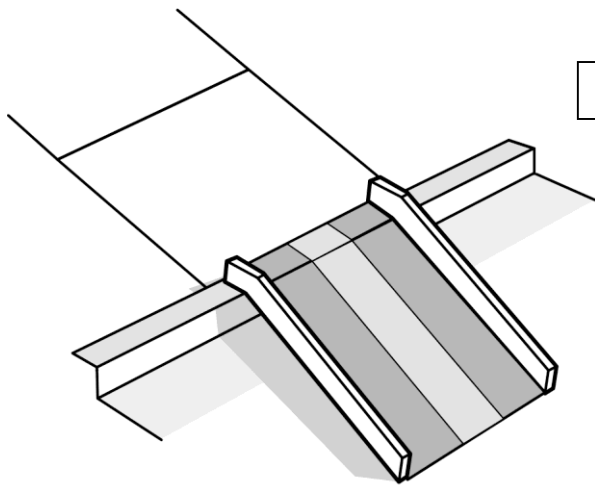
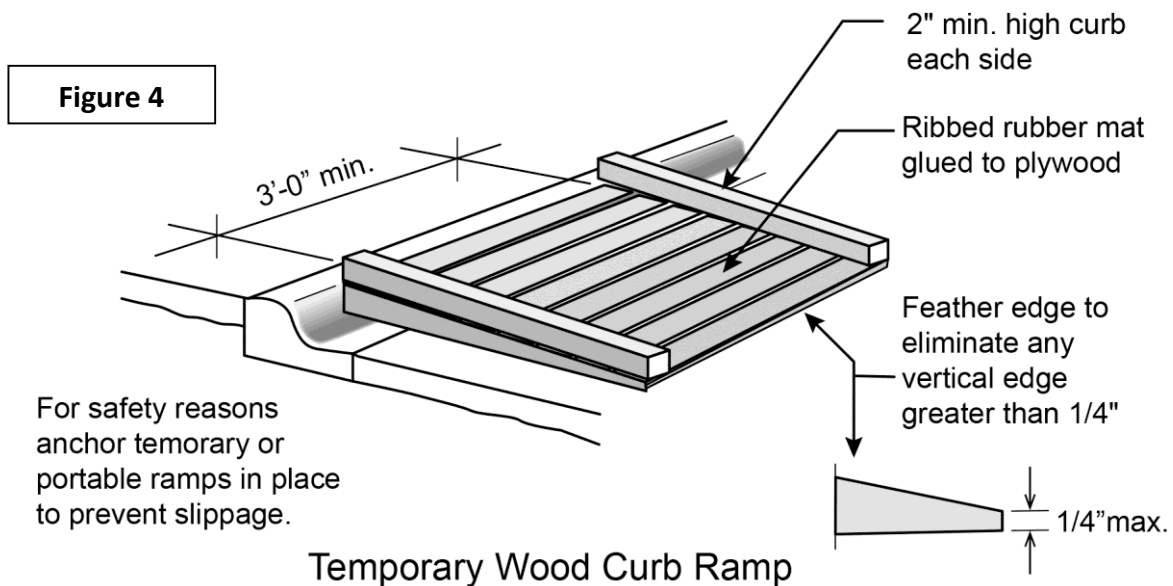

Figure 3

Manufactured Portable  
Curb Ramp



For safety reasons  
anchor temporary or  
portable ramps in place  
to prevent slippage.

Temporary Wood Curb Ramp

## Sidewalks

Pedestrian walks may have several changes of surface material along their length, for example, asphalt to concrete or concrete to brick. This can pose a tripping hazard or an obstacle to someone using a wheelchair. Weathering and tree roots may cause outdoor surfaces to crack or buckle, forming small hazardous drop-offs. All abrupt vertical changes greater than 1/4 inch should be repaired or, where appropriate, have small bevels installed to create gradual transitions (see Figure 20 on page 33).

## Barricades

Barricades are frequently used to create temporary access in areas normally reserved for vehicles. Barricades may be used to temporarily define maneuvering space for people

using wheelchairs or to protect a portable ramp location. Traffic cones and barrels, sawhorses, or even cinder blocks and wood planks also could be used, provided the barricade looks intentional, is heavy enough to remain stable during inclement weather, and resists vandalism. At least a 32-inch opening in the barricade must remain clear so people using wheelchairs may pass through but vehicles may not.

## PARKING

To use parking spaces safely, people with wheelchairs or other mobility aids need more space than is available at typical non-accessible parking spaces. Each accessible parking space must be equipped with a level access aisle to provide adequate space for car doors and van lifts to open and for users to maneuver. To conserve on space, two parking spaces may share one access aisle (Figure 5).

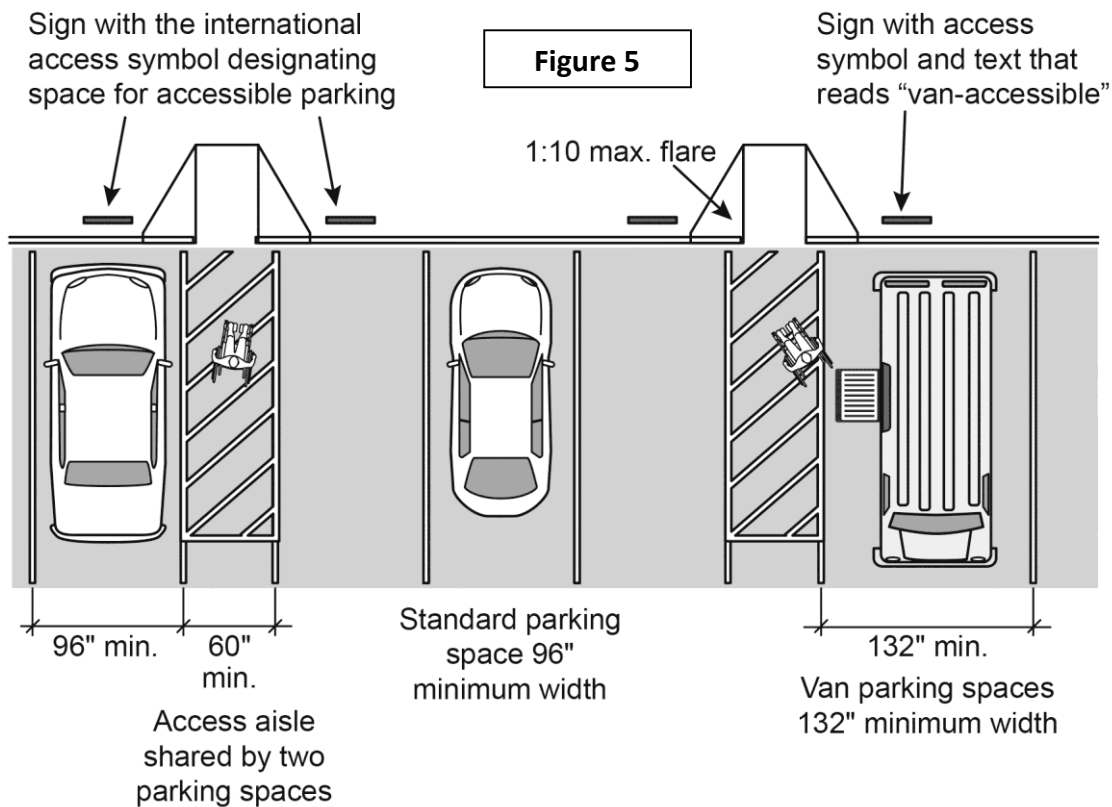

### Parking Spaces and Access Aisles

As many states have additional design requirements for accessible parking spaces, it is advisable to check your state and local building codes to ensure that your accessible parking spaces comply with both the ADA and state/local requirements. Accessible parking spaces must be as close as possible to a main event site or building entrance and be connected to that entrance by a smooth, level path without curbs or obstructions, i.e., an accessible route.

---

## Number of Accessible Parking Spaces Required

At a minimum, there should never be fewer accessible parking spaces than specified in the ADA Standards (Table 1). Of these, at least one in every six accessible parking spaces must be “van accessible.” Van spaces, to be usable, must be wider than those designed for cars.

**Table 1: Number of Accessible Parking spaces as Specified in the ADA Standards**

Total parking spots in lot	Minimum number of accessible spaces required*
1 to 25	1
26 to 50	2
51 to 75	3
76 to 100	4
101 to 150	5
151 to 200	6
201 to 300	7
301 to 400	8
401 to 500	9
501 to 1000	2 percent of total
1001 and over	20 plus 1 for each 100 over 1000

**\*Note that one of every six accessible spaces, or fraction of six, must be van accessible. For example, if eight accessible spaces are required, two of those eight spaces must be van accessible.**

## Accessible Vans

To provide sufficient room to deploy a lift, van accessible spaces should be at least 132 inches wide. For events catering to a specific audience, the number of accessible spaces may have to increase beyond the minimum if the event is directed toward a population consisting of a large number of people who have mobility disabilities, for example, a function specifically for people who are older.

## Location

**General:** Accessible parking spaces must be level and adjoin an accessible route to entrances. Accessible parking spaces should be placed as close as possible to the accessible entrance served by the parking area to minimize the need for a person with a disability to travel long distances to merely arrive at the entrance.

Ideally, all parking areas should have accessible spaces. However, if one lot is closer to the event entrance, it may be best to locate all accessible spaces in that lot. Covered parking or unloading areas should be available for people with disabilities, who often take longer to get into and out of vehicles.

**Parking Garages:** Parking garages may be problematic because the vertical clearance at the entrance may be too low to accommodate personal vans equipped with raised roofs, a feature on many accessible vans. As stated in the Standards, vertical clearance for van-accessible parking spaces and the vehicular route to them is 98 inches minimum. Some personal use vans require even greater clearance, thus a vertical dimension greater than 98 inches is recommended. (Figure 6).

**Note:** these are minimum vertical clearances, some vehicles will exceed 98" in height

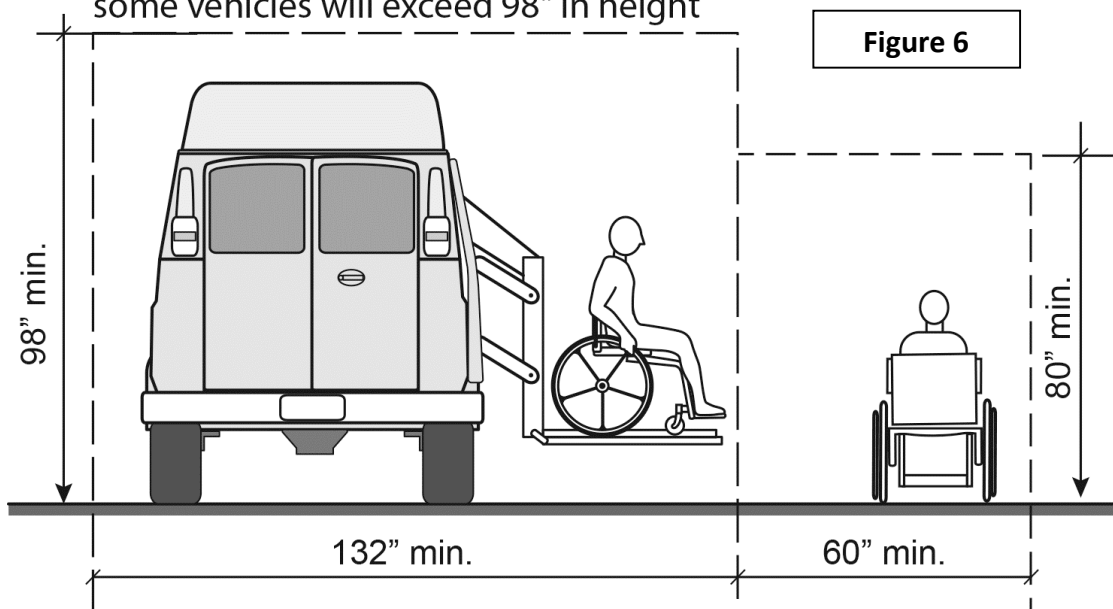

## Van Parking Space Vertical Clearance

Van-accessible spaces may be provided in alternate locations outside the garage, but as close as possible to an accessible entrance and at no additional inconvenience to the driver/passenger with a disability.

**Off-Site Parking:** If a significant portion of or all parking is located in areas not adjacent to the event site, accessible routes must be provided to and from accessible parking spaces in these areas. If the accessible route includes walks, streets, or parking facilities not under the control of the event organizer, it may be necessary to make prior arrangements to ensure that accessible spaces and routes to them are available.

Many of the temporary parking and walkway solutions presented in this chapter can also be used in off-site areas. One of the most critical issues is the use of curb ramps for crossing streets and parking lots. It may be possible to request that curb ramps be installed or to use strategically placed portable ramps as needed.

It may be best under these circumstances to create accessible, temporary parking on-site and indicate its availability both on directional signage and in publicity material.

---

It may also be possible to use accessible vans or buses to shuttle people from outlying parking areas. This may be a large commitment of resources for an event if the use of shuttles is not already being planned for the benefit of other event participants. However, if a shuttle service is planned, the shuttle must be accessible and accessible parking spaces must be available in lots served by the shuttle.

### **Parking Signage**

Each accessible parking space should be clearly marked with a vertical sign displaying the accessibility symbol. Wider spaces for vans should be designated as “van accessible.”

Signs for accessible parking must be positioned in strategic locations along the site if those spaces are not located within the general parking areas. It may be necessary to designate accessible parking along the street when parking lots have severe grades or parking garages have low vertical clearances.

### **Upgrading Out-of-Date Accessible Parking Spaces**

Accessible parking spaces that were built before passage of the ADA may not conform to current standards. The most common problems are insufficient number, narrow access aisles, and spaces that lack or have improperly designed curb ramps.

These problems should be corrected as much as possible to meet the Standards. If permanent changes are not possible or cannot be made in time for an event, temporary solutions should be made.

**Access Aisles:** Many access aisles are too narrow, i.e., less than 60 inches wide. To solve this you can block off the entire adjacent parking space and add that space to the access aisle, thus increasing the area available in which to maneuver a wheelchair or mobility aid. This also is a good method for providing additional space around an existing curb ramp that projects into access aisles.

**Curb Ramps:** Many existing curb ramps have slopes that are too steep, have too much surface warp or cross slope, and have insufficient room for a person using a wheelchair to turn out of the ramp onto a level area. These conditions are dangerous and can cause many who use manual wheelchairs to tip and fall.

A few solutions to address problem curb ramps include:

- Adding a temporary ramp at another location even if it is necessary to create a new access aisle. The easiest method is to designate an entire parking space for this purpose because no additional striping of the lot is necessary.
- Installing edge protection where none exists (Figure 7).

---

Edge protection prevents crutch tips and small caster wheels from slipping off edge of surface.

Figure 7

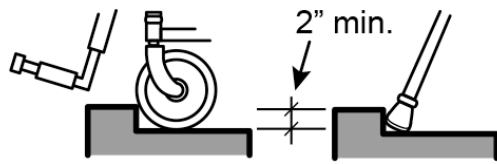

Curb Detail

Some people in manual wheelchairs, power wheelchairs, or scooters may be able to use steeper curb ramps (short run ramps) if the slope of the ramp is between 1:8 and 1:10 for a maximum rise of three inches or between 1:10 and 1:12 for a maximum rise of 6 inches. However, longer ramps are dangerous if they have a slope greater than 1:12.

Exposed drop-offs on curb ramps where no side flares are provided are a hazard, especially when crowds are present. Anyone could accidentally travel off the edge of the ramp and twist an ankle due to the abrupt level change. This condition is especially hazardous for people using wheelchairs who could be pitched out of their wheelchairs onto the pavement.

Railroad ties, planters, masonry blocks, and similar large objects set along the edge of an exposed drop-off can provide a warning and a physical barrier. Such objects should project at least two to four inches above the surface of the ramp. The best method to prevent an actual fall is to securely attach a permanent feature such as a return curb or side flare to the exposed edge of the ramp.

### **Creating Temporary Accessible Parking Spaces**

When necessary, temporary accessible spaces can be created in permanent paved lots, dirt lots, or fields.

**Existing Parking Lots:** Choose spaces that are level, close to an accessible entrance and near existing curb ramps. Mark or block off an existing parking space with cones, barricades, or pavement marking tape to create a new access aisle and use the accessibility symbol to designate the accessible spaces. If no existing curb ramps are available and the new parking spaces border on the sidewalk, place a portable curb ramp in the temporary access aisle to gain access to the sidewalk level (Figure 8).

**Figure 8**

When there is no accessible parking, an existing space can be temporarily used as an access aisle to make the spaces on either side of the aisle accessible.

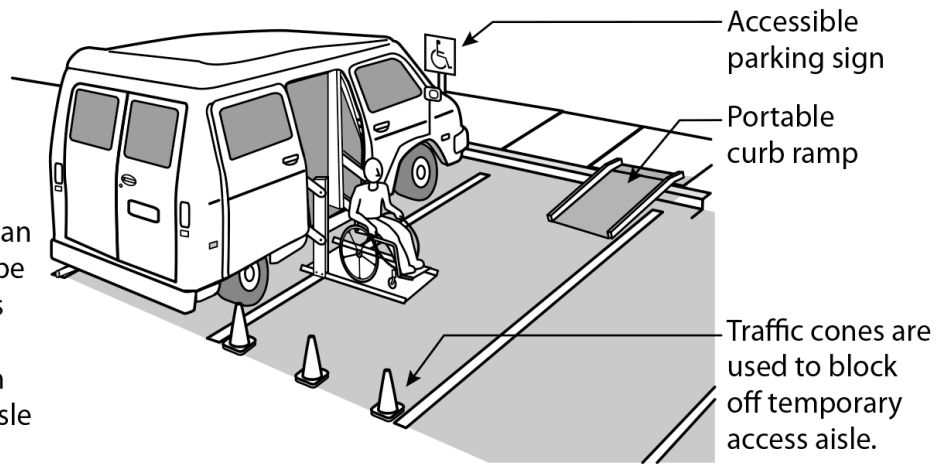

## Temporary Modifications to Permanent Site Feature

**Temporary Parking Lots:** Grass fields or dirt lots used as temporary parking areas usually have no marked spaces. Most likely, participants will arrive and be directed to a parking space. Accessible spaces must be created and held in reserve for people with disabilities.

Accessible parking spaces should be located where the surface is firm and stable. Dirt should be hard and compact and grassy areas closely cut to ground level. Loose sand, gravel, and overgrown grassy areas are too difficult to travel across for many people using wheelchairs or those who walk with difficulty. Sites that become slippery or muddy when wet will not be usable by everyone. If it is possible to find a paved lot with an accessible route, locate accessible parking there.

As with all accessible parking, those designated in temporary lots should be level and near accessible entrances. The space should be laid out in accordance with the Standards and identified with the accessibility symbol. Use crowd control fences, traffic cones, and/or similar barricades to set aside accessible parking areas, and designate each space with a sign displaying the accessibility symbol. Create an accessible route from the parking access aisles to the event entrance.

You may need to place plastic or rubber matting over unstable natural surfaces to make them navigable for short distances (see “Natural Surfaces” in Chapter 4).

People using wheelchairs should not have to travel behind parked cars or cross vehicular traffic lanes. If this is unavoidable, the pedestrian route (especially where the route crosses traffic lanes), access aisles, and parking spaces should be clearly defined. Methods and materials to use include chalk or aerosol paint, ropes and stanchions, crowd control fences, and barricades at key points.



## DROP-OFF AREAS

### Transit Stops

For many people, public buses, subways, and trams are the most convenient means of transportation. For others it is their only means.

If a public transit stop is not located on or near the event site, an accessible route from the transit stop to the site must be created. This route should have curb ramps.

**Accessible Routes:** A route to a transit stop usually is not accessible because it lacks curb ramps. For public sidewalks, ask the local city or county government to install curb ramps where needed or position portable curb ramps where they can be used safely.

If the alternate route deviates from a more direct inaccessible route, provide directional signage to alert the public of the accessible route to the event.

### Passenger Loading Zones

Provide an accessible space or passenger loading zone for shuttles and private vehicles to drop off and pick up participants safely outside the flow of traffic.

An accessible loading zone must have a vertical clearance of at least 114 inches for personal vans with raised roofs, buses, and paratransit vehicles. If there is not sufficient vertical clearance for raised roof vans or buses to pull underneath, you may need to create temporary loading zones in other locations to accommodate these vehicles. The space should be 20 feet long and at least eight feet wide with a five-foot-wide access aisle alongside the pull-up space for the vehicle (Figure 9).

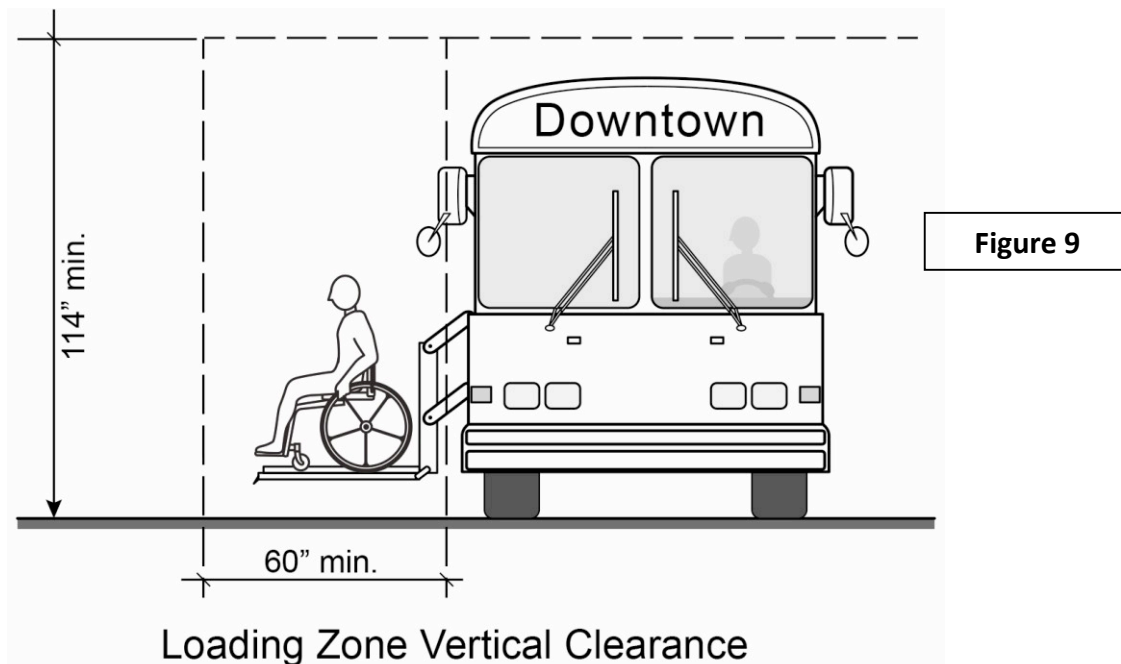

If an existing passenger loading zone lacks curb ramps, block a portion of the area off and use a portable curb ramp.

**Temporary Passenger Loading Zones:** Temporary passenger loading zones can be created by blocking off areas along streets and driveways or in parking lots. If the temporary passenger loading zone is located away from the event entrance, provide directional signage and an accessible route to the location (Figure 10).

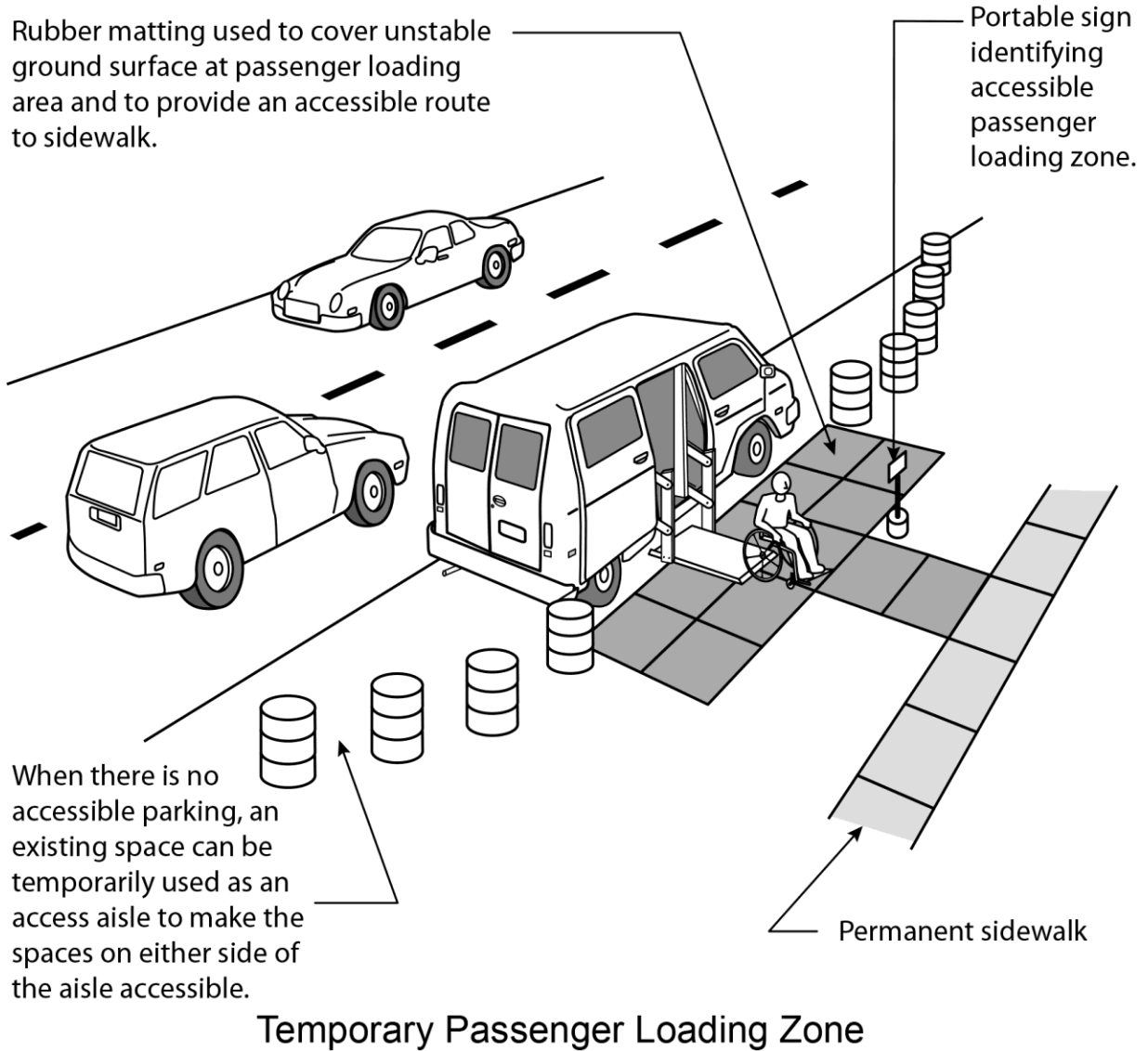

**Figure 10**

---

# CHAPTER Four – Participating in the Event

All event participants, including those with disabilities, must be able to get around the event site and view or take part in most activities, if not all.

The chapter is divided into two parts:

1. “Getting Around at the Event” focuses on the nuts and bolts of creating an accessible facility and emphasizes the importance of the accessible route to people with mobility and sensory disabilities.
2. “Taking Part in the Event” focuses on making the core activities of the event accessible, including programs, games, the exhibits, and performance areas.

## GETTING AROUND

### Space Requirements for Wheelchairs

Accessible routes ensure that people who use mobility aids can successfully navigate through the environment. A space that is a minimum of 30 inches wide by 48 inches long is necessary to park a wheelchair in a stationary position (Figure 11). The space necessary for people using wheelchairs to make a 180-degree turn is a circle with a diameter of 60 inches (Figure 12). Alternatively, a person can make a T-shaped turn, similar to a three-point turn in a car, at the intersection of a hall, between display cases, or where some of the space necessary to perform the turn may be under a counter or table (Figure 13).

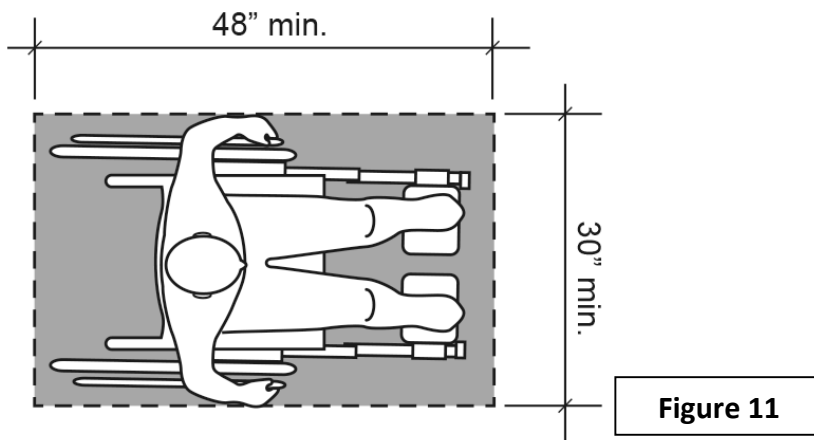

Figure 11

Minimum Clear Floor Space  
for Wheelchair

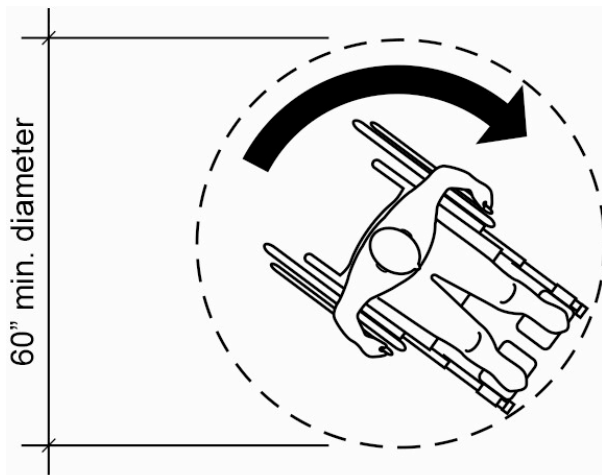

Figure 12

Pivoting Turn Space

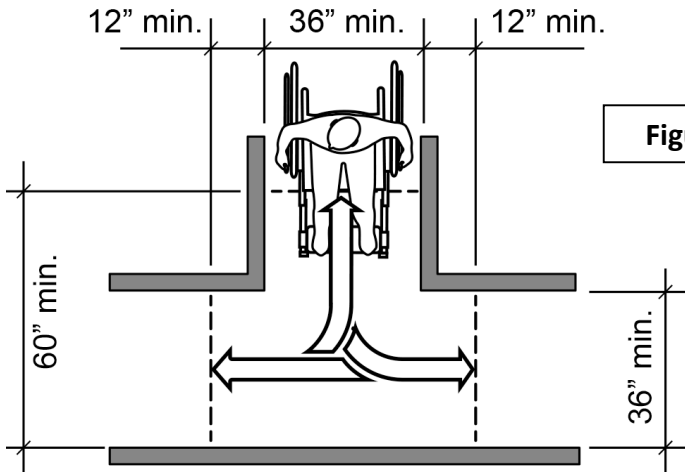

Figure 13

T-Turn Space

### Accessible Route

Individuals who use wheelchairs or walking aids or who walk with difficulty need an accessible route of travel throughout the event site. A successful accessible route connects site arrival points and parking with all exterior and interior event exhibits and activities, including public amenities, such as toilet rooms, water coolers, and telephones (Figure 14).

This single continuous path should:

- Be smooth, but not slippery.
- Be as level and as wide as possible without low or overhanging hazards or obstructions.
- Not require the use of stairs.

**Figure 14**

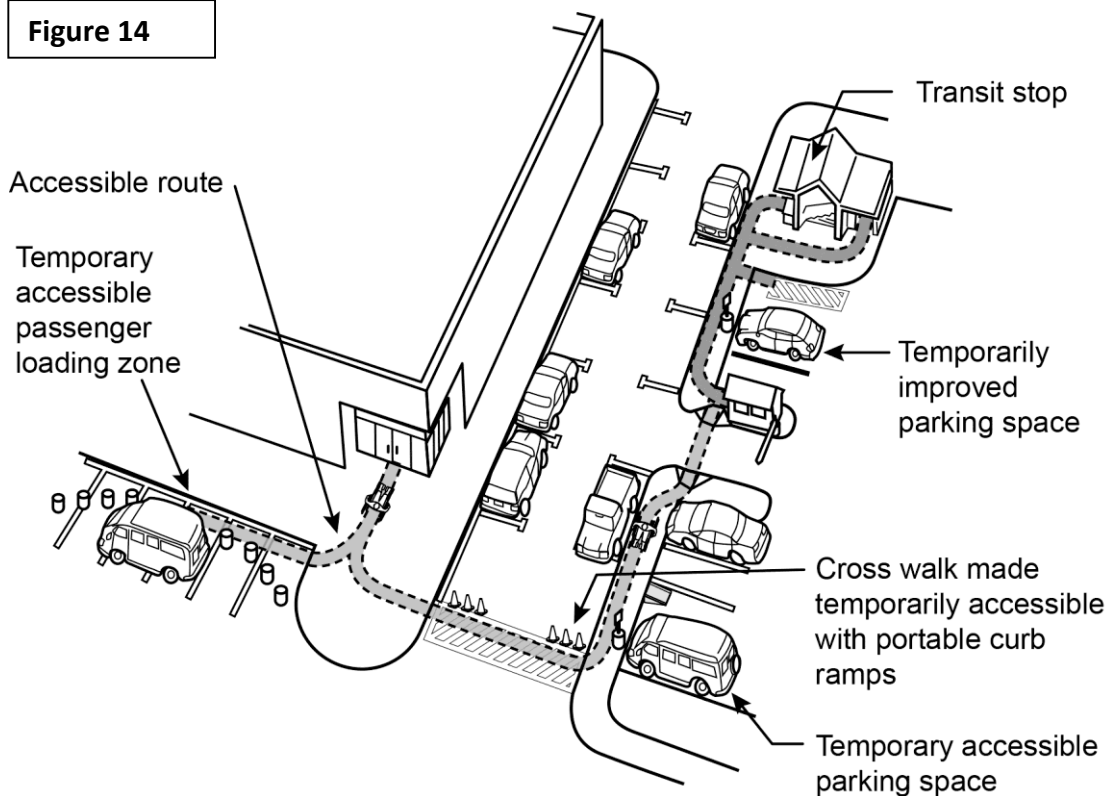

### Accessible Parking and Drop-off Points Must Be Located on an Accessible Route that Connects to Accessible Entrances

As much as possible, the accessible route should be the same route used by other participants. Modifications to create accessible routes may be temporary or as permanent as resources allow. Once a route has been mapped out, it must be identified with signs if it deviates from paths used by the general public.

An accessible pedestrian route must meet these requirements (see Figure 1 on page 8):

- Be at least 36 inches wide. Exception: at doors or short passageways, where the accessible route may be reduced to 32 inches in width for a maximum distance of 24 inches.
- Have a minimum 60-inch by 60-inch clear space, at least every 200 feet, so two people using wheelchairs may pass.
- Have a minimum of 80 inches vertical clearance or headroom along its entire length.
- Be free of any hazardous, protruding objects.
- Be on stable, firm, slip-resistant and compact surfaces.
- Slope no more than 1:20 unless a ramp with handrails and edge protection is installed. Ramps are limited to a slope of 1:12. All cross slopes are limited to 1:48.
- Have no abrupt vertical changes in floor or ground level unless it is limited to 1/4 inch with vertical changes between 1/4 inch and 1/2 inch permitted only if the change is beveled with a slope of 1:2 or less.
- Level changes greater than 1/2 inch, such as a step, stairway, or full floor level, can be accomplished using a ramp, lift, or elevator.

---

## Entrances

After arriving on the site, participants with disabilities must be able to get to and through entrance gates and building entrances. The accessible route to these entry points must be free of stairs unless a ramp, lift, or elevator is also provided. Ideally, people with disabilities should use the same entrance as other visitors; modifications may be needed to accomplish this. An inaccessible entrance can be made accessible by installing a portable ramp or lift (Figure 15).

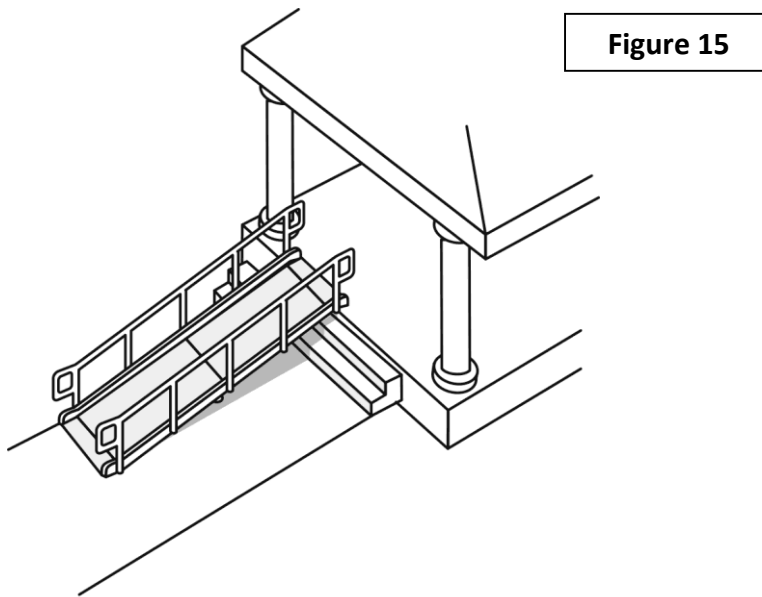

Portable Ramp Used at  
Inaccessible Building Entrance

If necessary, an alternate entrance that can be more easily altered should be selected. Use signs displaying the International Symbol of Accessibility to direct visitors to accessible entrances.

There are at least three entry door and gate conditions unique to building entrances that may require attention.

1. **Revolving Entry Doors.** The ADA Standards prohibit revolving doors from being part of an accessible route. Often, one or more swinging doors are placed adjacent to revolving doors, usually intended as emergency or service entrances (Figure 16). These auxiliary doors may be used as the accessible entrance during a temporary event as long as the doors remain unlocked and, if no door hardware is present or door closers are too heavy, they are propped open or held open by staff.



Auxiliary Door at Inaccessible Revolving Door

Figure 16

2. **Entry Vestibules are not accessible.** Double door vestibules, where maneuvering space is limited, can trap people using wheelchairs. There should be at least four feet between the second door in its open position and the first door. If this is not the case, the inside or second door can be removed or propped open for the event (Figure 17).

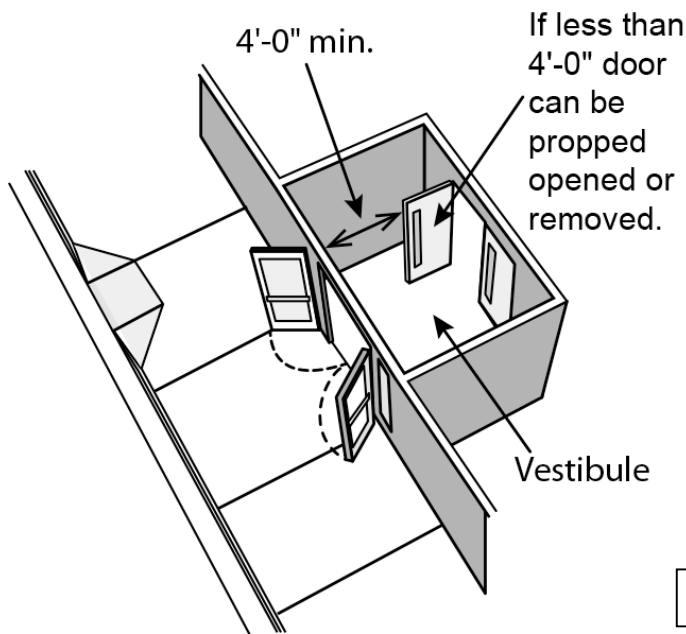

Figure 17

Double Door Entry Vestibule

3. **Turnstiles are not accessible.** An alternate accessible route must be provided and, if possible, placed close to the entrance used by other participants. Security guards or other personnel must be prepared to allow people with disabilities to pass through auxiliary or service gates as needed (Figure 18).

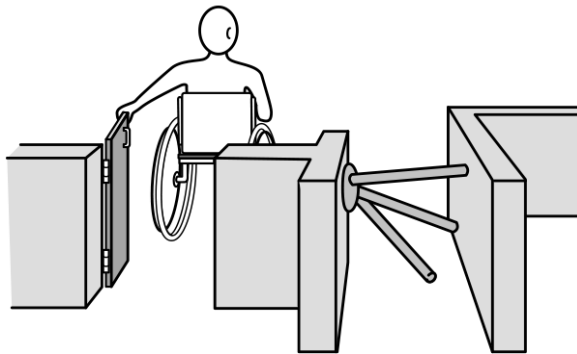

Figure 18

Auxiliary Gate at Turnstile

## Ground and Floor Surfaces

Rolling over soft loose surfaces such as deep pile carpet, sand, or gravel is difficult or impossible for most manual wheelchair users. People who use powered wheelchairs or scooters may also have difficulty on these surfaces since extra force is required to travel across them. This can drain batteries quickly and could leave a person stranded.

Irregular surfaces, such as cobblestones and similar uneven brick or concrete pavers, are uncomfortable as these can cause wheelchairs to rock and tilt. Unstable and uneven surfaces also can be a problem for people who walk using crutches or canes, often causing a loss of balance or falls.

## Natural Surfaces

Crushed stone or soil—if compact, stable, and free of loose debris—is often a usable surface on which to hold a temporary event. If the surface is grass, it too may be serviceable if the soil is not soft and the grass is cut close to the ground. Tall grass is often slippery and difficult to roll a wheelchair across.

Weather affects the usability of exterior surfaces. A grass playing field, acceptable in dry conditions, can become slippery and muddy after a rain. For some activities, it may be a good idea to have an alternate indoor location available.

Synthetic matting can provide a temporary compact and stable surface over sand, gravel, or wet areas. Low profile, non-slip rubber doormats might work for short distances provided their edges are secured or beveled.

Interlocking rubber tiles are probably the best method of providing an accessible route over unstable ground surfaces, especially when long distances must be covered. Perforated plastic mats are another good option because they do not kill the grass they are covering.



## Grates and Grilles

A grate or grille located in the accessible route must not have any openings wider than 1/2 inch in the direction of pedestrian travel (Figure 19). Openings any larger can catch the tips of crutches or canes and wheelchair wheels, causing the occupant to pitch out of the wheelchair. Hazardous grates can be covered or blocked off or the accessible route redirected.

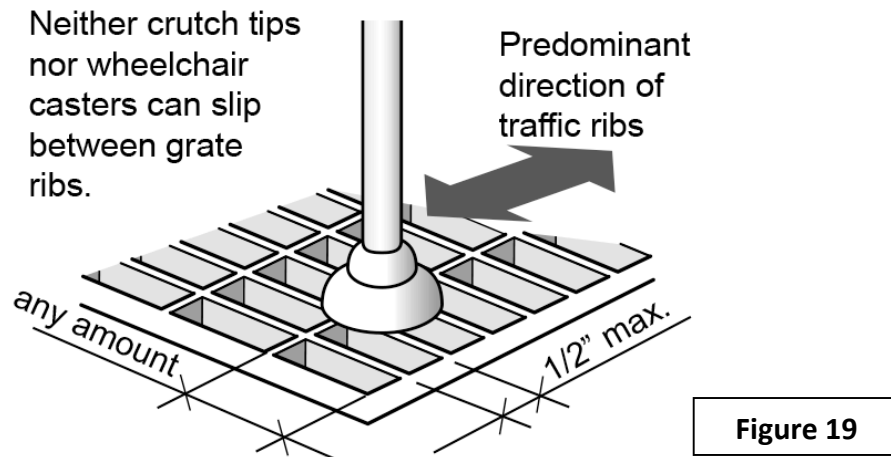

### Grate Opening in Pedestrian Travel Direction

## Carpet

Soft carpet is a common problem in many buildings. Deep, thickly padded or loosely woven carpets are the most difficult to travel across. Where large numbers of participants with disabilities are expected, and/or where travel distances over soft carpet are long, try to reroute the path for all the event participants or, a less desirable alternative, reroute the accessible route. The accessible route should coincide as much as possible with the route used by the other event participants. Rolled surface materials may be laid over existing carpet, provided the resulting surface is firm, not spongy or difficult to roll a wheelchair or walk across.

Loose carpet edges are tripping hazards and can catch the wheels of wheelchairs and scooters and should be fastened or taped down. Throw rugs and mats should be secured or removed.

## Small Abrupt Vertical Changes

Small, abrupt vertical level changes often occur where surface materials change, such as from asphalt to concrete or brick to wood. This condition also can result as surfaces become buckled or cracked from wear or weather. Smooth transitions are always best because they also eliminate tripping hazards. However, people using wheelchairs and scooters can negotiate vertical changes of up to 1/4 inch.

Small abrupt vertical changes should be repaired or small bevels installed to create gradual transitions. Changes of 1/4 to 1/2 inch can be transitioned with a bevel sloped as steeply as 1:2. Small changes greater than 1/2 inch must slope at 1:20 (or in the case of a ramp, 1:12) (Figure 20).

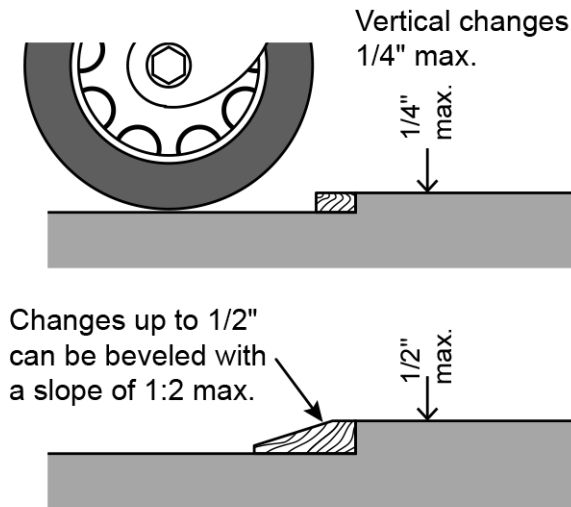

Figure 20

### Small Abrupt Vertical Changes

Bevels can be created with wood or other material planed into a wedge shape. For sidewalks and other concrete surfaces, it may be possible to trowel additional concrete onto cracked and uneven areas to smooth and level out the surface. If a vertical level change is high enough, it may require the use of a ramp, lift, or elevator.

### Changes in Ground and Floor Levels

Change in level is one of the biggest obstacles to traveling about a site and entering or moving within a building. If an area has an inaccessible change in level, it may be possible to redirect the accessible route and make use of other pathways and entries that do work or can be easily modified. If an alternate route is not possible or would require a person with a mobility disability to travel an excessively long distance, level changes can be overcome by installing ramps or platform lifts or making use of existing elevators.

Existing facilities, ramps and elevators may not meet the specifications of the ADA Standards and should be evaluated for adequacy and safety.

### Temporary Ramps & Lifts

A temporary ramp may be a good solution if stairs have a total rise of no more than 30 inches. (A ramp designed to allow someone in a wheelchair to safely climb a 30-inch change in level must be at least 30 feet long). Bridging a greater change in level would require a ramp longer than would be practical for a temporary situation.

Temporary ramps intended for use by the general public should comply with the ADA

Standards specifications for ramps. There is some leniency in the degree of ramp slope (with rises of 6 inches or less) in existing buildings and facilities where space is extremely limited. Ramps onto stages for a performer or presenter may be designed according to the individual's needs. If these limited use ramps are steep they must be supervised during use and assistance must always be available.

Key specifications for ramps that comply with the ADA Standards (Figure 21):

- A minimum width of 36 inches between handrails.
- A maximum slope of 1:12 (1 inch of rise for every 12 inches of run).
- No more than 30 inches of rise in a run before a landing or level resting platform.
- Slopes in existing facilities with extreme space limitations are restricted to between 1:10 and 1:12 for a maximum rise of 6 inches and between 1:8 and 1:10 for a maximum rise of 3 inches.

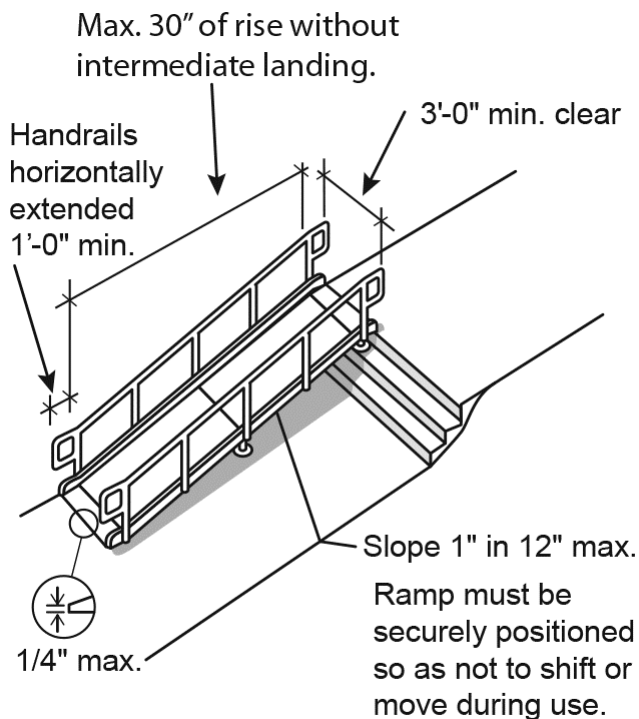

Figure 21

### Portable Manufactured Ramp

Manufactured portable ramps are equipped with all necessary features of an ADA complying ramp, i.e., appropriate width, slope, length of run, edge protection, easy-to-grip handrails, and non-slip surfaces. Temporary ramps can be made from plywood and lumber. If exposed to exterior conditions for long periods of time or if reuse is anticipated, these ramps should be constructed of treated wood or otherwise be weather protected. Note: Ramps with a rise of six inches or less do not need to have handrails, but must have curbs or another form of edge protection to prevent a user in a wheelchair from rolling off ramp sides.

---

Portable ramps must not move, shift, or wobble when in use. They must be securely attached or designed to remain stationary at all times.

### **Temporary Platform Lifts**

Platform lifts may be a solution for stairs with a rise higher than 30 inches but not a full floor level. They also can transport people when the level change is less than 30 inches but there is insufficient space to install a ramp. In some localities, it is possible to rent portable lifts from medical equipment dealers, independent living centers, or lift and elevator companies.

### **Elevators**

Existing cabs must be at least 36 inches wide by 54 inches deep to be accessible. Since this does not allow a person in a wheelchair enough room to turn around, a larger cab provides greater usability for a wide range of people who use wheelchairs, scooters, and other mobility supports. At events where there may be large numbers of people using mobility aids and traveling between floors, elevators should be large in size and in number.

A freight or service elevator is the solution of last resort for people with mobility disabilities to get between floors. It can be used if it is the only option. Staff may be required to operate it. Provide signs directing participants to the “out-of-the-way” usable elevator.

Even if cab size is adequate, other details should be considered to increase accessibility. If necessary, add stick-on raised numbers on elevator jambs at each floor level and raised numbers and/or Braille at control panels that lack tactile numbering to aid people with visual disabilities.

### **Doors**

Doors must be wide enough for a person using a wheelchair to pass through and be easy to open and close.

Doors must have a 32-inch clear opening for people using wheelchairs to pass through without bumping sides. This usually means the door itself should be 34 inches wide, but 36 inches is preferable. A door having a clear opening narrower than 32 inches can be used by many people with disabilities provided the door can stand open and sufficient space is available on either side of the door for a person using a wheelchair to line up with the opening before passing through.

There are some easy ways to enlarge a door opening by nearly two inches. When privacy, security, and air conditioning/heating requirements allow, the entire door leaf could be removed to gain clear opening width. Existing standard door hinges can be replaced with swing-away hardware, which allows the door leaf to swing completely out of the door opening.

---

## **Door Opening Force**

Interior doors should never require more than five pounds of force to open and, if possible, eight pounds for exterior doors. Doors requiring excessive force can be propped open. Removing a closer or lessening its force is also an option for some doors. **Door Handles.** Change knob handles to accessible lever or loop types if possible. Otherwise, consider propping doors open.

## **Eliminating Hazardous Protruding and Overhanging Objects**

All interior and exterior circulation paths used by event participants and staff, including accessible routes and stairs, must be free of any objects that protrude from walls and posts, or hang from ceilings. Examples are signs, fire extinguishers, light fixtures, drinking fountains, valve controls, standpipes, parts of exhibits, sculptures, partitions, tree limbs and tent guy wires.

A wall-mounted object must not protrude more than four inches unless its bottom edge is detectable by a person with a visual disability using a long cane for navigation. The bottom of the protruding object must be no more than 27 inches above the floor, otherwise it must be mounted above 80 inches. Any standing object that protrudes more than 12 inches from its base requires an element at or below 27 inches so that it is detectable with a walking cane. Vertical headroom must always be at least 80 inches where a circulation path passes under an object or overhanging feature.

Temporary walls must be installed so as not to be hazardous. Overhead bracing must not violate the 80-inch minimum headroom requirement and the bottom of display panels must be detectable.

## **Tents, Tarps, and Similar Temporary Structures**

Guy wires for such structures should either be located out of pedestrian pathways or have a detectable barrier or element as a warning device. Support framework must also be evaluated for potential hazards and, if necessary, modified.

## **Information and Ticketing**

The entrance gate, main desk, or information booth must be accessible in the design and location of the space and in the information provided.

Information and ticketing areas must be located on an accessible route that connects all event areas, from parking to the exhibits or activities offered. A section of the counter or desk should be available that is no higher than 36 inches and at least 36 inches long so people seated in wheelchairs and those of short stature can conduct business or review information.

Front-line staff at information and ticketing areas must have a thorough knowledge of accessible features and services offered by the event and a general sensitivity to disability issues. If staff is prepared, requests for information, directions, or assistance

---

can be effectively and appropriately addressed (see “Preparing Staff and Volunteers” in Chapter 2).

If resources permit, some brochures, maps, or schedules should be available in large print for people with limited or low vision. Such literature can be enlarged on copy machines. Staff should be prepared to read literature aloud if requested by participants with visual disabilities.

For large events with multiple activities or where event directions or instructions are complicated, consider preparing an audio cassette tape that could be loaned, along with an economical cassette player, to people with visual disabilities or others who may not be able to read printed material. This may be more involved than possible for most events, but could be a successful solution for some.

Event directories, although exempted from conformance with the ADA Standards, should meet the general requirements of non-glare finish, character proportion, and type size to provide ease of use for all visitors

## **Signage**

Clear, easy-to-read signs placed in consistent locations help visitors find their way around an event site and learn about activities or exhibits.

Permanent building and site signs should be evaluated for their adequacy and, when possible, upgraded by facility owners to comply with ADA Standards below.

### **Permanent Identification of Rooms and Spaces**

- Tactile characters and Braille
- Upper case sans serif or simple serif 5/8” to 2” in height min. 1/32” raised
- High contrast and non-glare finish
- Mounted 48” – 60” above the floor on the wall adjacent to the latch side of the door
- Allow visitors to get close enough to read and touch signs.

### **Informational and Directional Signs**

- Simple design—no extended or condensed type
- High contrast and non-glare finish
- Characters should be sized according to viewing distance (characters should be larger on overhead signs or signs that people can’t approach closely).

### **Temporary Signs**

If existing room signs are difficult to read or are too small, temporary signs should be added if possible.

Although temporary signs do not have to meet the ADA Standards, they should conform to the specifications for “directional” signs above, if possible.

---

Use standard or common words on signs. For example, signs that are “theme-oriented” (e.g., “buoys” and “gulls” or “kings” and “queens” denoting men’s and women’s restrooms) may not be understood by many people with cognitive disabilities. People with low vision will not be able to read signs that are highly decorative, printed on glossy surfaces, or poorly lit.

Where only some routes are accessible, include the international symbol of accessibility on signs for accessible routes, parking spaces, passenger loading zones, entrances, and toilet and bathing facilities. Display the appropriate sign at text telephones and telephones with volume controls. Use the symbol of access for hearing loss in assembly areas with assistive listening devices.

Execute hand lettered signs in printed rather than cursive lettering. It is possible to purchase manufactured signs that comply with the ADA Standards.

Note: A Braille embosser can be used to augment partially complying signs by adding vinyl adhesive Braille labels. However, only a small percentage of the population that is blind reads Braille. Braille signs are most useful for the independent repeat building user who uses signs to confirm their own location within a building or space.

## TAKING PART IN EVENT

### Exhibits and Displays

The ADA Standards do not cover the design of elements that are not part of or attached to a building. Thus, portable display tables, cases, shelves, or panels that are generally transported into temporary event space are not required to meet ADA Standards. However, under Titles II and III of the ADA, it is expected that participants will be able to experience full enjoyment of the event.

### Making exhibits and displays accessible

Locate display tables, cases, shelves, or panels next to an accessible route and have adequate space for a person using a wheelchair or scooter to pass behind other participants who have stopped to examine an object.

- Mount **free-standing display cases** between 36 and 39 inches high. Objects that are viewed from above should be no higher than 36 inches. Carefully placed mirrors can also bring otherwise obscured surfaces into view. If high displaycases or bookcase style shelving are used, it may be necessary to take items out of cases or off high shelves so a person with a disability can view and study an object up close.
- Make sure the bottom deck of **wall-hung display cases or objects** is between 36 and 39 inches off the ground.

- 
- Space limitations often dictate that items be exhibited on vertical bookcase style **display shelves**, putting many objects above the preferred viewing height of 36 to 39 inches. Try to place a representative sample of items in the preferred range and be prepared to bring items on high shelves to participants upon request.
  - Provide enough space for a person to sufficiently back away from and closely approach the **display panel** to view items displayed.
  - The height for **mounting flat images** (e.g. photographs, paintings, and maps) must allow both standing people and people who use wheelchairs to view the image comfortably.

### **Large Objects**

Large objects, or objects to be entered such as trucks, boats, or aircraft, pose unique problems to access. Some cannot be accessed without requiring significant modification of the object itself.

For many temporary events, the only practical solution is to provide a video “tour” of the object that provides an experience similar to that of actually physically entering the object. A representative model showing key features or a life-sized mock-up can also allow the participant to experience the key features of the object.

If there are numerous objects on display, such as at a boat or antique car exhibit, a representative selection could be made accessible or again, video “tours” could be provided.

In exhibit spaces with accessible mezzanine or viewing balconies such as coliseums, large objects can be strategically located so that parts of the object difficult to see from the main floor level can be viewed from an upper level.

### **Exhibits in Trailers**

Traveling carnivals and fairs may include exhibits entirely contained in trailers accessed by climbing a set of three to five steps. The content of the exhibit must be available to all participants, and vendors should provide a brochure of the exhibit for people who cannot enter. A preferable solution is to add a temporary/removable ramp or lift at the entrance. These modifications could become permanent parts of the equipment that travels from site to site to display the exhibit.

### **Creating Access for People with Sensory Disabilities**

**Visual Disabilities.** People with visual disabilities can understand much about objects on display if they have the opportunity to touch and handle the object in a way that allows them to perceive its weight, texture, shape, etc. Duplicate or example objects can be offered for this purpose. Relief maps with three-dimensionally project features, and scale models of large objects can also provide valuable information. If all people are



---

allowed to touch these “tactile” exhibits, it makes the experience more educational and memorable for everyone attending the event.

Provide spoken narrative or an audio component to describe the content of two dimensional images. Staff members can also describe images for a specific participant or, if someone is explaining the exhibit to all participants, he or she can present a more detailed description so a person with a visual disability may acquire a full understanding.

**Hearing Disabilities.** People with hearing disabilities must have access to the content of audio/visual presentations, such as slide shows and videos. Ideally, such presentations would have captions or subtitles of the audio component. Otherwise, the spoken word could be presented in a written script. Where only ambient sounds are used, this should be noted so participants with hearing loss know they are not missing a part of the exhibit.

### **Artwork, Crafts, and Other Wares for Sale**

The ability to see, reach, and study objects or images is key to selecting an item to purchase. Ideally, a person with a mobility disability should be able to move about the vendor’s entire display space. Vendors should use the same guidelines as those used for exhibits and displays, discussed earlier in this chapter.

Vendors may need to take items down from high shelving, bring small items closer to an individual, or carry an object completely out of the display space.

### **Participating in Activities**

Many temporary events have activities that require or encourage visitor participation, such as question and answer sessions, art activities, games, competitions, workshops, or impromptu speeches.

Inclusion is the emphasis for all activities. However, in some rare instances having separate divisions in an event will actually allow people with disabilities to participate in a more equal manner. For instance, in a marathon competition having a wheelchair division separate from the men and women’s divisions actually allows people with disabilities to participate with peers as other members of the community. However, many runners with braces or artificial limbs will want to compete in regular men and women’s divisions. A flexible policy will allow participants with disabilities to choose the division in which they feel the most comfortable.

### **Physical Accessibility**

The level of access for people with mobility disabilities will vary with the nature of the activity. For example, an individual with a mobility disability may not be able to use a trampoline, but there still must be an accessible route to the location so the individual may accompany friends or supervise children.

**Surfaces.** For activities that require a surface area, such as writing, painting, or model

---

building, some tables or portions of counter tops must be accessible. The ADA Standards require that 5%, but never less than one of all fixed or built-in tables and seating, be accessible, with adequate knee space and at appropriate heights for people using wheelchairs or needing to sit.

For some situations, such as a potter's wheel or an arcade game, it may be possible to dedicate resources to make or acquire an accessible version to offer a representation of the experience. In some instances, assisting participants may be the only practical alternative.

**Exhibits and Displays with Controls.** Interactive displays should have controls that are usable by all people, i.e., levers, loop handles, push buttons, and rocker switches. These usually require little force to operate and are common enough that operation is intuitive for most participants.

Toggle or "joy stick" type handles and trackballs are also easy to use by people with limited hand function. When it is not possible for all exhibits to have accessible controls, a few representative examples equipped with such controls should be provided to assure that a general sense of the experience is available for everyone.

### **Eliminating Communications Barriers**

Activities that require communication to participate should be conducted in a manner that allows participation by people with hearing, vision, or speech disabilities.

**Hearing Disabilities.** For group discussions, workshops, or question-and-answer situations, all visitors must be able to understand the information presented and respond in as unrestricted manner as possible. Assistive listening devices should be available for people with limited hearing. The most useful are portable systems that allow flexibility for small group or classroom situations (see "Assistive Listening Systems," page 43).

For many people with hearing loss, the use of sign language interpreters is essential for two-way communication to occur. While this may be impractical or costly for a single activity, it may be possible to have a pool of interpreters on hand for larger entertainment events that can be sent to activities as requested. There should be some scheduled accessible/interpreted performances that are advertised in advance. To find qualified sign language interpreters in your area, contact your ADA Regional Center (Chapter 6.).

**Vision Disabilities.** People with vision disabilities may need to be physically close to visually presented information, instructions, or activities, e.g. maps, artwork, photographs, etc. For those for whom this will be ineffective or who are blind, additional explanations may be necessary in order to convey essential themes and facts. As with exhibits, sample objects may be made available for participants to touch and feel.

**Cognitive or Developmental Disabilities.** Keep instructions simple and presented in short sentences. Instructions for people with cognitive disabilities are more effective if participants must act after each direction. Presenters need to be patient and willing to integrate everybody into the activities as much as possible.

## Assembly Areas

Speeches, performances, and sports exhibitions involve a significant number of people gathered in a defined space. Assembly areas, whether in permanent indoor facilities or temporary outdoor settings, must be accessible, both in the design of facilities and in how the program is offered.

This section mainly addresses assembly areas without fixed seats, i.e., gymnasiums that rely on movable seating, large meeting rooms where furniture and stages must be brought in, and large open spaces where there may be no defined seating.

**Wheelchair Seating Locations.** Assembly areas with fixed seating, e.g. theaters, stadiums, etc., must provide a range of built-in seating locations so people using wheelchairs can choose where to position themselves to view activities or performances. The number of wheelchair locations required is related to seating capacity and, with some exceptions, must be dispersed within conventional seating areas so patrons have a choice of ticket price. These goals also should be met or exceeded in assembly areas where moveable chairs are used for the temporary event. (See Table 2.)

**Table 2: Number of Wheelchair Seating Locations Required in New Construction**

Capacity of Seating in Assembly Areas	Number of Required Wheelchair Seating Locations
4 to 25	1
26 to 50	2
51 to 150	4
151 to 300	5
301 to 500	6
501 to 5000	6, plus 1 for each 150, or fraction thereof
5001 and over	36, plus 1 for each 200, of fraction thereof

**“Classroom” Style Layouts.** Wheelchair seating locations must have additional space between the rows of tables for maneuvering space and for a person using a wheelchair to pull up under a table so others may pass behind.

**“Theater” Style Layouts.** “Theater” style layouts are commonly used for temporary events. Chairs can be set up in the usual manner, except that clear floor space must be allocated for wheelchair seating locations. Chairs can be strategically eliminated along aisles and at the back or front of seating areas to create spaces so people using wheelchairs can park beside other participants without obstructing pedestrian traffic.

---

**Open Areas.** Where there is no fixed or temporary seating and participants are expected to sit on the ground, the most level areas should be designated for accessible seating. These spaces should be held in reserve for a specified period of time before others may occupy those areas. Care must be taken in the placement of cables, supports, and other stage or electronic equipment so accessible routes can be maintained.

### **Access to Performing Areas**

Access to performing areas is an issue when there are performers or presenters with disabilities or when members of the audience may be expected to come on stage and participate in the presentation.

**Accessible Route to Performing Areas.** Where performing and viewing areas are at different levels, it may be possible to create a direct route between them using portable ramps or lifts (see “Changes in Ground and Floor Levels,” page 33). Where the audience will not go up to the stage, access for a performer or presenter may be provided via an accessible route through a backstage or other support area not used by the general public. When audience participation is anticipated, such routes are not ideal because it requires people with disabilities to take a route segregated from other participants. However, in many older facilities this may be the only realistic alternative.

**Speakers’ Platform.** A common arrangement for many events is to have several speakers present together at a single table. A speakers’ platform with a typical 30-inch wide and 72-inch long table should be a minimum of 8 feet wide by 16 feet long to allow enough maneuvering room for people using wheelchairs and space for a sign language interpreter. To prevent speakers from accidental falls, place platforms against a wall to eliminate one edge. Locate tables and/or install a curb to eliminate exposed drop-offs of platform edges.

**Microphones.** Table microphones and lapel or lavalier mikes should be provided for people with mobility disabilities, especially people with limited use of their hands. It might be necessary to raise a mike by placing it on blocks or use a mike stand with a horizontal boom for people using wheelchairs.

## **Eliminating Communications Barriers**

Eliminating communication barriers to people with sensory disabilities is a fundamental part of making the entire program accessible.

### **Assistive Listening Systems**

People with varying levels of hearing loss make up a large percentage of the population with disabilities. The ADA requires listening systems in assembly spaces where audible communications are integral to the use of the space and an audio amplification system is available. These listening systems pick up voice/music directly from the source and then direct it to the listener who can adjust the volume to their needs. Most listening systems eliminate or reduce background noise so people with special receivers or their own

hearing aids can adjust the volume and hear the sound more clearly.

The minimum number of receivers needed is based on the seating capacity of the space (see table below). Receivers need only be available for the performance, so it may be possible to share the receivers between activities and presentations. An efficient system must be established to enable people to check-out and return receivers. Receivers must be provided at no cost to users, but individuals can be required to leave a valid ID or a minimal, returnable deposit to obtain a receiver.

The availability of the listening system should be indicated by signage using the international symbol of access for hearing loss (see “Accessibility Symbols” on page 13).

**Table 3. Receivers for Assistive Listening Systems**

<b>Capacity of Seating in Assembly Area</b>	<b>Minimum Number of Required Receivers</b>	<b>Minimum Number of Required Receivers Required to be Hearing-aid Compatible</b>
50 or less	2	2
51 to 200	2, plus 1 per 25 seats over 50 seats, or fraction thereof	2
201 to 500	2, plus 1 per 25 seats over 50 seats, or fraction thereof	1 per 4 receivers, or fraction thereof
501 to 1000	20, plus 1 per 33 seats over 500 seats, or fraction thereof	
1001 to 2000	35, plus 1 per 50 seats over 1000 seats, or fraction thereof	
2001 and over	55 plus 1 per 100 seats over 2000 seats, or fraction thereof	

There are three types of listening systems currently in use:

1. An audio loop system consists of an amplifier and a wire antenna embedded in the floor or walls or taped to the surface around a designated seating area. It sets up a magnetic field that can be picked up by some users with hearing aids or others wearing a telecoil equipped receiver and an ear piece. There is a new technology known as a 3-D mat that has much less spillover and is less susceptible to electromagnetic interference.
2. Infrared systems use light beams to transmit information to users wearing receivers with neckloops or headphones. Infrared systems offer confidential transmission, but, because infrared light is present in natural and artificial lighting, well-lit rooms sometimes produce interference. Infrared systems can be used in any seat in the facility, provided the seat has an unobstructed line of sight to the transmitter.

- 
3. FM systems work similarly to the infrared but operate on FM radio frequencies, do not require an unobstructed line of sight, and are unaffected by sunlight. However, where there are multiple events, different frequencies will need to be used. The FM system collects sound from either a microphone or public address system and then uses a transmitter to send the signals to small receivers. Hearing aid users with “T” (telephone) switches on their hearing aids wear receivers with a neckloop listening attachment which generates a magnetic field picked up by the telecoils. Other users must wear receivers equipped with earphones and a volume control to hear the amplified sounds. FM systems are portable and very reliable.

### **Placement**

If the listening system serves individual seats, it is recommended that those seats be located within a 50-foot viewing distance of the stage or play area. At this distance, viewers can distinguish facial expressions and pick up other small gestures which help them interpret the actions of performers.

A wide variety of options and variables must be considered in planning effective and manageable listening systems for people with hearing disabilities. Manufacturers, organizations of people with disabilities, and service providers are good sources for additional information and advice.

### **Sign Language Interpreters**

For many people with limited or no hearing, assistive listening devices are not adequate and a sign language interpreter is needed. Generally, an interpreter is located at the end of the speaker’s table or on a raised step directly behind the speaker. A wide contrasting solid background should be hung behind the interpreter to eliminate visual background clutter and make it easier to see interpreter hand positions. The interpreter should be well-lit and audience members with hearing disabilities must have an unobstructed view or be allowed to sit in front of the interpreter.

There are interpreters who are very good at mimicking the facial expressions and gestures of performers. Interpreter “actors” may work well for plays and stage productions to convey the full range of feelings and concepts inherent in an artistic performance. It may be possible that a selected performance of a particular work augmented with such interpreters could be scheduled and publicized ahead of time.

### **Text Display**

Text display is another method of access for people with hearing disabilities. Spoken narrative, song lyrics, or character dialog can be displayed in a variety of ways, including overhead projection, use of electronic text display panels, captions or subtitles.

Computer-aided real-time reporting (CART) may be required in situations with no set dialogue. A stenographer types dialogue into a computer, which displays the text on a monitor or screen. At least one showing of videos, films, or slide presentations should be accompanied with captions or subtitles, and these should be publicized ahead of time.

---

## **Availability of Scripts or Text of Performance**

A script of a performance can be made available so it can be read ahead of time or during the performance. While lacking a real time one-to-one relationship, this approach can be effective for complicated pieces of work, such as plays or operas. Where multiple works are staged, at least a representative performance should be offered with accompanying text.

## **Audio Descriptions**

Audio descriptions should be provided for performances that are mostly visual in nature or where key information is visually presented. Descriptions and explanations of visual elements could be recorded on audio cassettes and given out as requested. A one-to-one description could be provided where someone sits with a person who is blind and voices descriptions.

## **Seating Options**

Seating location will be helpful to many people with hearing and vision disabilities. Many people with limited vision can discern much in the way of color, shape, and movement if they can sit close to the performance. Likewise, people with hearing disabilities can effectively see the hand movements of sign language interpreters, displayed text, or the gestures of actors if they are close enough. Some seating in the front rows of assembly areas should be held in reserve for people with hearing and vision loss.

## **Games and Amusement Rides**

Games are typically offered at most fairs, carnivals, and street festivals. Such activities, by their very nature, are participatory, and should have the same level of both physical and communication access as established for other kinds of participatory activities. Event sponsors and organizers should work with individual vendors to ensure the maximum degree of access. Some games require certain minimum levels of physical ability. For example, a game of ring toss or a turkey shoot requires the participant be able to see and be able to use one or both arms and hands. This game could not be modified to allow someone who could not see or use their arms to participate. However, games must be accessible to the maximum extent feasible.

High counters and railings that hold the participants back a prescribed distance from the game are common barriers. The mounting height of operable parts of equipment, e.g., water gun for a marksmanship game, should be considered. Often such heights are chosen because they work well for standing adults. Vendors should consider making at least one of the stations accessible for people using wheelchairs or adults of short stature. Video and other arcade style games such as pinball function essentially like exhibits with controls (see “Exhibits and Displays with Controls,” page 38).

Many carnival amusement rides are completely inaccessible to people with mobility disabilities and difficult to make accessible. Portable and mobile amusement rides at temporary events are exempt from ADA Standards, but there may be ways to improve access and facilitate participation in some cases (see Chapter 10 of the 2010 ADA

---

Standards for guidance).

## **Concessions**

Concessions offered by the event organizer and those offered by individual vendors should be accessible.

## **Food and Drink**

Many of the ADA specifications for fixed facilities (restaurants, cafeterias, etc.) can be used in making temporary food service counters, trailers and tables accessible. The height of service counters must not exceed 36 inches. Food and drink offered from mobile trailers may need to install a low folding shelf.

While other accommodations may still be needed when actually serving food, condiments and menus can be placed on this auxiliary shelf within easy reach. It also may be possible for event vendors to jointly provide a condiment table in or adjacent to nearby eating areas.

People with mobility disabilities should be able to reach each area provided for dining and should be able to pull up under at least five percent of the tables. There must be an accessible route to the area and adequate maneuvering space around and under tables.

Where there are no tables near eating areas, consider providing one or two and some chairs. Such a courtesy will be helpful for many people with conditions that affect balance or stamina and who have trouble eating while standing or traveling.



---

# CHAPTER Five – Service and Support Facilities

Support services and amenities that are provided to the general public, such as restrooms, telephones, and drinking fountains must be provided in an accessible manner to people with disabilities.

It is not necessary to provide emergency medical services to people with disabilities beyond what is available to the general public. If a person with a disability is having physical or medical difficulty and is able to communicate, ask the person directly what is the most appropriate course of action. Never assume you know what is best for that person.

## TOILET FACILITIES

Every toilet room available to the public should have at least one toilet and lavatory fixture that is accessible to people with disabilities. For older facilities, modifications need to be made to the greatest extent possible. It may be necessary to rely on accessible facilities in adjacent buildings or sites. If this is the case, provide directional signage to these accessible toilet facilities.

### **Portable toilet units (also known as port-o-lets or port-a-potties)**

ADA Standards require that at least five percent of portable toilet units must be accessible. The number and design of these units are discussed on page 51.

### **Toilet Room Doors and Vestibules**

Doors should provide a 32-inch clear opening to accommodate people using wheelchairs and other mobility aids. If toilet rooms have privacy screens or vestibules where the door can stand open and yet privacy is still maintained a simple step such as propping the door open or removing it altogether may suffice.

Where leaving doors open will compromise privacy, a temporary privacy screen such as standard exhibit booth curtains can be installed outside the room.

### **Toilet Room Clear Floor Space**

Toilet rooms must have a 5-foot diameter clear floor area to allow someone in a wheelchair to turn around or a 3-foot wide T-shaped clear floor area to allow for a three-point turn.

Sometimes just removing or relocating freestanding objects, such as trashcans, may help free up floor space. Generally, modifications that increase maneuvering area must be of the type that are permanent, i.e., removing or rearranging stall partitions or creating knee space under lavatory counters. It may be necessary to look at other toilet spaces in the facility or in adjacent areas and direct people as necessary.

## Toilet Stalls

Multiple fixture toilet rooms must have at least one accessible stall as required in new construction (Figure 22). Clearance around a toilet shall be 60 inches (1525 mm) minimum measured perpendicular from the side wall and 56 inches (1420 mm) minimum measured perpendicular from the rear wall.

Stalls must be located on an accessible route.

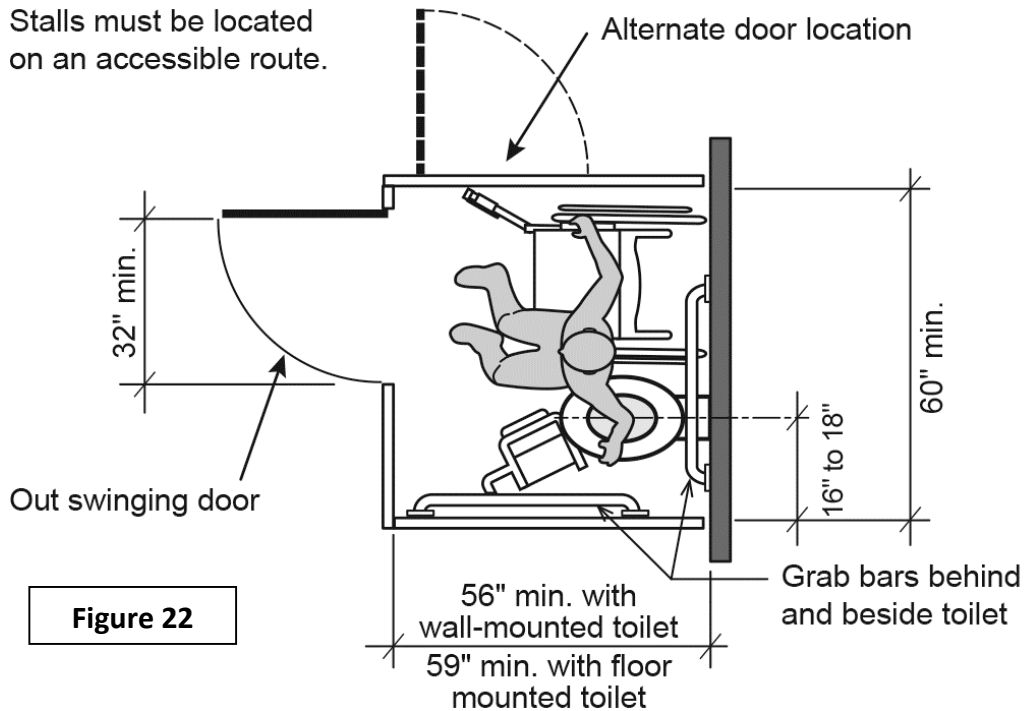

Standard Accessible Stall

If a wheelchair-accessible stall does not exist in a toilet room and there is no practical way to furnish one temporarily, a wide stall may be created by combining two conventional sized stalls and removing one toilet fixture. This does require permanent modifications such as the installation of new partitions and grab bars and the repair or replacement of floor and/or wall coverings.

While it may be difficult to provide a standard accessible stall, there are modifications that can be undertaken more easily to improve existing narrow conventional stalls that can be done as part of “barrier removal” efforts. This is permissible only for Title III entities (private businesses and nonprofit service organizations) where it is not “readily achievable” to meet the design requirements of the ADA Standards.

The recommended steps for improving the usability of a narrow stall are:

- Select a stall against a wall — preferably at the end of a room or row.
- Install 42-inch minimum length grab bars on each side of the stall, located 12 inches maximum from the rear wall and extending 54 inches minimum from the rear wall, with a height of 33 to 36 inches above the floor. These must be well

---

anchored to support a 250 lb. load in all directions. This is a permanent modification that should be requested of the building owner.

- Remove existing narrow door and wall side doorjamb.
- Install overhead rod and privacy curtain.

Only a small minority of people in wheelchairs may actually be able to use such modified stalls. People who walk with the aid of crutches or canes find this narrow stall very useful because the close parallel bars are available for support when sitting down and rising. In fact, in toilet rooms with six or more stalls constructed since the implementation of the ADA, the installation of a 36-inch wide stall is required in addition to the standard accessible stall.

### **Lavatories, Mirrors, and Dispensers**

Lavatories should have a 27-inch clearance between the bottom edge of the apron and the floor. Faucets should have lever and wand type handles that can be operated without grasping or twisting.

Mirrors located above lavatories or countertops shall be installed with the bottom edge of the reflecting surface 40 inches maximum above the finish floor or ground. Mirrors not located above lavatories or countertops shall be installed with the bottom edge of the reflecting surface 35 inches maximum above the finish floor or ground.

Depending on the direction of reach, towel and soap dispensers should be no higher than 48 inches unless located over a counter or fixture where they are limited to 44 inches above the floor. When existing conditions vary from these parameters, some simple steps can be taken to make the existing fixtures more readily usable.

Countertop aprons made of materials such as synthetic marble can be cut back to provide the necessary knee clearances. Exposed hot water and drain pipes under lavatories should be insulated to prevent burns on the legs of people using wheelchairs. This is required for the accessible lavatory.

If towel dispensers and mirrors are too high, it is usually less costly and quicker to mount a new towel dispenser nearby and install a full-length mirror on another wall than it is to relocate existing ones. The full-length mirror is good for everyone to use.

Some towels can be placed on a shelf or table within reach of seated or short people. If a soap dispenser is too high, make regular cake soap or pump bottles available. Freestanding trash receptacles should be located so they do not interfere with wheelchair maneuvering space.

Many people who use wheelchairs can, with difficulty, use a lavatory that does not have the standard 27-inch minimum clearance under the apron. For this reason, it still is prudent to undertake the above cited modifications and temporary measures even if this clearance cannot be provided.

---

## Single-User Toilet Rooms

While beyond the scope of modifications required for a temporary event, a new accessible single-user or unisex toilet room is an excellent long-term cost-effective way to provide accessible lavatories. Large sites with multiple buildings can have a centrally located freestanding accessible toilet room. There are manufactured single-user and small public toilet rooms available that apply accessibility requirements in their design.

## Portable Toilet Units

If portable toilets are provided for use by event participants, a minimum of five percent of all units, but never less than one unit, must be accessible. Where clusters of portable units are provided at various locations around the event site, five percent of the units in each cluster should be accessible. They should be equipped with all the accessible elements required by the Standards such as maneuvering space, grab bars, toilet paper dispensers within reach, etc. In addition, when all units are not accessible, the International Symbol of Accessibility must be posted on the units that are.

Portable toilet units are being manufactured that meet all of the specifications of the Standards. However, some portable toilet units promoted as accessible do not contain sufficient interior floor space.

Some also make use of a ramp that slopes directly up to the entrance door making it difficult or impossible for people in wheelchairs to climb the ramp and pull the stall door open at the same time. While these units are helpful to some people, they still are not accessible to many others.

Accessible portable toilet units must be positioned on a level area that connects with an accessible route and have adequate space just outside the entrance door for people in wheelchairs to maneuver into position to open the door and enter. On steeply sloping sites, a temporary platform may be needed to provide this level area.

The door threshold must be accessible. Outdoor surfaces are often uneven and may require a small bevel to level out the transition between the ground surface and door threshold. Units can be placed on or adjacent to parking lots or other paved surfaces.

## AVAILABILITY OF DRINKING WATER

Drinking water should be readily available to all people. Some people with disabilities must drink fluids regularly and/or are susceptible to dehydration or becoming overheated. Consider the duration and size of the event and evaluate the adequacy of existing drinking fountains. Availability of water may be of secondary concern for small brief meetings but is critical for large or lengthy events.

Concessionaires who offer soft drinks and juices also should provide water. If only a few or no drinking fountains are available, consider adding portable water containers or coolers placed in easy-to-find accessible locations, e.g., at information/courtesy booths.

---

Controls to release water should be easy to use and require little hand pressure. Latches and levers are preferred; avoid push buttons.

Ideally, there should be some “high” drinking fountains for taller standing people or people who have trouble bending over and “low” fountains for children, people using wheelchairs, or people of short stature. An equal mix of “high” and “low” is required in new construction but may not be present in older facilities. Older model drinking fountains usually have controls and water spouts that are too high for many people. Most people using wheelchairs and scooters can use drinking fountains if the spout is no more than 36 inches above the floor with controls located toward the front of the unit. An accessible fountain has knee space to allow someone using a wheelchair to pull up under the basin and better reach the spout and controls.

If existing fountains are too high, provide paper cup dispensers mounted no more than 48 inches above the floor with enough floor space for a person using a wheelchair to get close to the fountain. If drinking fountains have foot-operated controls, a cup dispenser should be installed and staff should be prepared to assist as necessary.

## **SHELTER**

If the event is outdoors and temperatures are extreme— above 80 degrees or below 50—arrange for access into facilities with more moderate temperatures. For large outdoor events, have at least one accessible outdoor shelter in each major activity area, particularly if access into adjacent buildings is not possible.

Make existing shelters accessible or create new accessible temporary shelters using tents or tarps. Temporary shelters should be located on level ground adjacent to an accessible route. Locate shelters close to existing water fountains or, in areas where this may not be possible, provide water in portable containers.

---

# CHAPTER Six – Resources

For an excellent source of ADA information, contact the ADA National Network by calling 1-800-949-4232 V/TTY, or through the website <http://adata.org/>.

The ADA National Network can also refer you to other national and regional resources that can help you locate and secure necessary support for your event, such as:

- event officials/managers who have successfully addressed accessibility issues for previous events;
- individuals with disabilities who work with the various local disability organizations;
- federal and state government agencies for publications and training;
- architects, designers, or organizations who have experience in the interpretation and application of accessibility codes and standards;
- professionals in the construction industry with experience in architectural; and modifications for accessibility.

## ADA NATIONAL NETWORK REGIONAL CENTERS

The ADA National Network consists of 10 regional centers that are located throughout the United States.

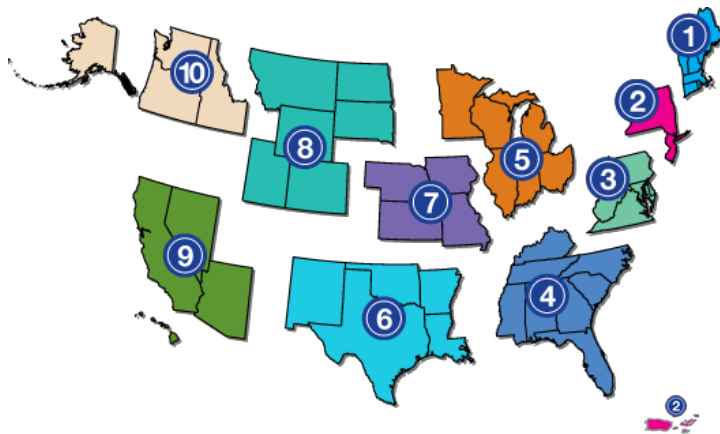

The ADA Regional Center that covers that State where your event is taking place will offer regional expertise and resources. Contact information for ADA Regional Centers is below.

Region 1 (Connecticut, Maine, Massachusetts, New Hampshire, Rhode Island, Vermont)  
**New England ADA Center**

Institute for Human Centered Design

200 Portland Street

Boston, MA 02114

617-695-0085 V/TTY

[adainfo@newenglandada.org](mailto:adainfo@newenglandada.org)

[www.newenglandada.org](http://www.newenglandada.org)

Region 2 (New Jersey, New York, Puerto Rico, U.S. Virgin Islands)

---

**Northeast ADA Center**

203 Dolgen Hall  
Ithaca, NY. 14853  
607-255-6686  
northeastada@cornell.edu  
[www.northeastada.org](http://www.northeastada.org)

Region 3 (Delaware, District of Columbia, Maryland, Pennsylvania, Virginia, West Virginia)

**Mid-Atlantic ADA Center**

401 North Washington Street, Suite 450  
Rockville, MD 20805  
301-217-0124  
adainfo@transcen.org  
[www.adainfo.org](http://www.adainfo.org)

Region 4 (Alabama, Florida, Georgia, Kentucky, Mississippi, North Carolina, South Carolina, Tennessee)

**Southeast ADA Center**

1419 Mayson Street  
Atlanta, GA 30324  
404-541-9001  
adasoutheast@law.syr.edu  
[www.adasoutheast.org](http://www.adasoutheast.org)

Region 5 (Illinois, Indiana, Michigan, Minnesota, Ohio, and Wisconsin)

**Great Lakes ADA Center**

University of Illinois at Chicago  
Institute on Disability & Human Development (MC 728)  
1640 West Roosevelt Road, Room 405  
Chicago, IL. 60608  
(312) 413-1407 V/TTY  
info@adagreatlakes.org  
[www.adagreatlakes.org](http://www.adagreatlakes.org)

Region 6 (Arkansas, Louisiana, New Mexico, Oklahoma, Texas)

**Southwest ADA Center at ILRU**

TIRR Memorial Hermann Research Center  
1333 Moursund St.  
Houston, Texas 77030  
713.520.0232  
swdbtac@ilru.org  
[www.southwestada.org](http://www.southwestada.org)

Region 7 (Iowa, Kansas, Missouri, Nebraska)

---

**Great Plains ADA Center**

100 Corporate Lake Drive  
Columbia, MO 65203  
573-882-3600 (V/TTY)  
adacenter@missouri.edu  
<http://www.gpadacenter.org/>

Region 8 (Colorado, Montana, North Dakota, South Dakota, Utah, Wyoming)

**Rocky Mountain ADA Center**

3630 Sinton Road, Suite 103  
Colorado Springs, CO 80907  
719-444-0268  
adainfo@adainformation.org  
[www.adainformation.org](http://www.adainformation.org)

Region 9 (Arizona, California, Hawaii, Nevada, the Pacific Basin)

**Pacific ADA Center**

555 12th Street, Suite 1030  
Oakland, CA 94607  
510-285-5600 (V/TTY)  
adatech@adapacific.org  
[www.adapacific.org](http://www.adapacific.org)

Region 10 (Alaska, Idaho, Oregon, Washington)

**Northwest ADA Center**

Center for Continuing Education in Rehabilitation  
University of Washington  
6912 220th St SW #105  
Mountlake Terrace, WA. 98043  
425-248-2480  
nwadactr@uw.edu  
[www.nwadacenter.org](http://www.nwadacenter.org)

## **ASSISTIVE TECHNOLOGY RESOURCES**

ASSISTIVETECH.NET -- The National Public Website on Assistive Technology

Phone: 404-894-4960 (V/TTY)  
Email: [catea@coa.gatech.edu](mailto:catea@coa.gatech.edu)  
[www.assistivetech.net](http://www.assistivetech.net)

AbleData

Phone: 800-227-0216 or 703-356-8035. (Se habla español).  
TTY: 703-992-8313.  
Email: [abledata@neweditions.net](mailto:abledata@neweditions.net)  
<http://www.abledata.com/abledata.cfm>



## FEDERAL AGENCIES

<p>ADA Information Line at U.S. Department of Justice Civil Rights Division, Disability Rights Section</p>	<p>950 Pennsylvania Avenue, NW Civil Rights Division Disability Rights Section - NYA Washington, D.C. 20530</p> <p>Talk to an ADA specialist: 800-514-0301 (voice) 800-514-0383 (TTY) Section Phone Number: (202) 307-0663 <a href="http://www.ada.gov/">http://www.ada.gov/</a></p>
<p>Federal Communications Commission</p>	<p>445 12th Street, SW Washington, DC 20554 888-225-5322 (voice) 888-835-5322 (TTY) <a href="http://www.fcc.gov/cgb/dro">www.fcc.gov/cgb/dro</a></p>
<p>U.S. Access Board</p>	<p>1331 F Street, NW Suite 1000 Washington, DC 20004-1111 800-872-2253 (voice) 800-993-2822 (TTY) <a href="http://www.access-board.gov">www.access-board.gov</a></p>
<p>U.S. Department of Education National Institute on Disability and Rehabilitation Research (NIDRR)</p>	<p>Potomac Center Plaza 550 12th St., SW, Rm. 6029 Washington, DC 20202-2700 202-245-7338 <a href="http://www2.ed.gov/programs/nidrr/index.html">http://www2.ed.gov/programs/nidrr/index.html</a></p>
<p>U.S. Department of Education Office for Civil Rights</p>	<p>Lyndon Baines Johnson Department of Education Bldg 400 Maryland Avenue, SW Washington, DC 20202-1100 800-421-3481 877-521-2172 (TTY) <a href="http://www2.ed.gov/about/offices/list/ocr/index.html">http://www2.ed.gov/about/offices/list/ocr/index.html</a></p>
<p>U.S. Department of Transportation ADA Assistance Line</p>	<p>888-446-4511 (voice) TTY: use relay service <a href="http://www.fta.dot.gov/ada">www.fta.dot.gov/ada</a></p>
<p>U.S. Department of Transportation Project Action, Federal Transit Administration</p>	<p>400 Seventh Street, SW Washington, DC 20590-0001 800-659-6428 (voice) TTY: use relay service <a href="http://www.projectaction.easterseals.com">www.projectaction.easterseals.com</a></p>
<p>U.S. Equal</p>	<p>131 M Street, NE</p>

Employment Opportunity Commission	Washington, DC 20507 For publications: 800-669-3362 (voice), 800-800-3302 (TTY) For questions: 800-669-4000 (voice), 800-669-6820 (TTY) <a href="http://www.eeoc.gov">www.eeoc.gov</a>
U.S. Department of Labor's Job Accommodation Network	800-526-7234 (voice) 877-781-9403 (TTY) <a href="http://www.askjan.org">www.askjan.org</a>

## STATE AGENCIES

Although the titles may vary, each state has an individual designated to act in the capacity of an ADA Coordinator. This position may be through the state’s Department of Administration or Department of Human Resources. Each state also has its own protection and advocacy service system to help educate and protect people with disabilities about their rights under the law. Contact the National Disability Rights Network for the protection and advocacy agency in your area.

National Disability Rights Network  
900 Second Street, NE, Suite 211  
Washington, DC 20002  
Phone: 202-408-9514  
Fax: 202-408-9520  
220-408-9521 (TTY)  
<http://www.ndrn.org>

## CENTERS FOR INDEPENDENT LIVING

There are approximately 403 Independent Living Centers throughout the U.S. and Puerto Rico, American Samoa, Guam, the Virgin Islands and the Northern Mariana Islands, with at least one located within each state. These Centers can be a valuable source for products and services available in or around the city where your event is being held. Independent Living Research Utilization (ILRU) in Houston, TX has an online directory of Centers available at [www.ilru.org](http://www.ilru.org)

ILRU at TIRR Memorial Hermann  
TIRR Memorial Hermann Research Center  
1333 Moursund Street  
Houston, TX 77030-3405  
713.520.0232 (Voice/TTY)  
Email: [ilru@ilru.org](mailto:ilru@ilru.org)

---

## Disclaimer

This information product was developed under a grant from the Department of Education, NIDRR grant number H133A110014. However, the contents do not necessarily represent the policy of the Department of Education, and you should not assume endorsement by the Federal Government.

## Suggested citation

ADA National Network. (2015). A Planning Guide for Making Temporary Events Accessible to People with Disabilities [booklet].

**© Copyright 2015 ADA National Network. All Rights Reserved.**

**May be reproduced and distributed freely with attribution to ADA National Network  
([www.adata.org](http://www.adata.org)).**



## Accessibility of State and Local Government Websites to People with Disabilities

The Internet is dramatically changing the way that American government serves the public. Taking advantage of new technology, many State and local governments are using the web to offer citizens a host of services including:

- corresponding online with local officials;
- providing information about government services;
- renewing library books or driver's licenses;
- providing tax information and accepting tax returns; and
- applying for jobs or benefits.

These government websites are important because they:

- allow programs and services to be offered in a more dynamic, interactive way, increasing citizen participation;
- increase convenience and speed in obtaining information or services;
- reduce costs in providing programs and information about government services;
- reduce the amount of paperwork; and
- expand the possibilities of reaching new sectors of the community or offering new programs.

When government is constantly being asked to do more with less, the Internet is playing a vital role in allowing government to better serve all of its citizens.

The Americans with Disabilities Act (ADA) and, if the government entities receive Federal funding, the Rehabilitation Act of 1973, generally require that State and local governments provide qualified individuals with disabilities equal access to their programs, services, or activities, unless doing so would fundamentally alter the nature of their programs, services, or activities or would impose an undue burden. One way to help meet these requirements is to ensure that government websites have accessible features for people with disabilities, using the simple steps described in this document. An agency with an inaccessible website may also meet its legal obligations by providing an alternative accessible way for citizens to use the programs or services, such as a staffed telephone information line. These

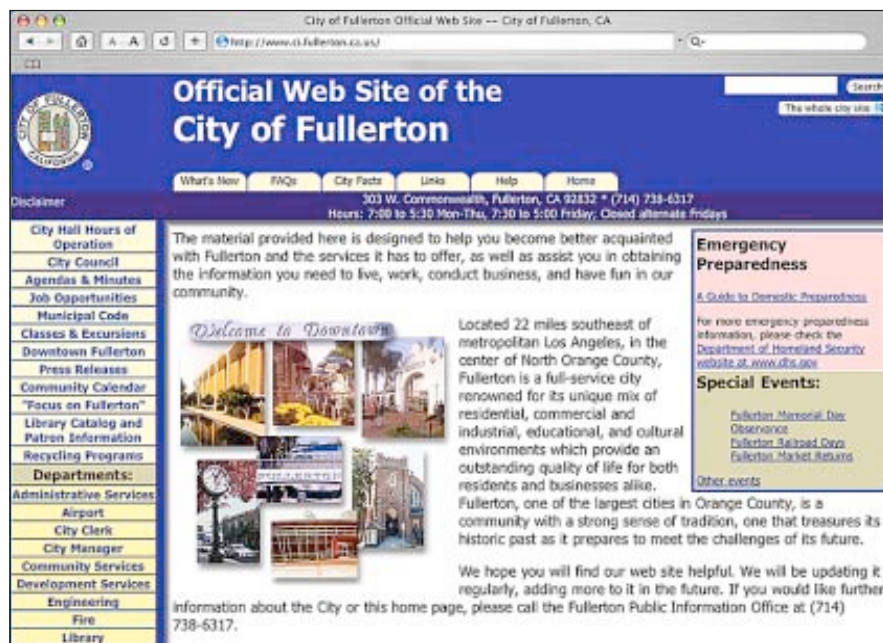

alternatives, however, are unlikely to provide an equal degree of access in terms of hours of operation and the range of options and programs available. For example, job announcements and application forms, if posted on an accessible website, would be available to people with disabilities 24 hours a day, 7 days a week.

## Online Barriers Faced By People with Disabilities

Many people with disabilities use “assistive technology” to enable them to use computers and access the Internet. Blind people who cannot see computer monitors may use screen readers – devices that speak the text that would normally appear on a monitor. People who have difficulty using a computer mouse can use voice recognition software to control their computers with verbal commands. People with other types of disabilities may use still other kinds of assistive technology. New and innovative assistive technologies are being introduced every day.

Poorly designed websites can create unnecessary barriers for people with disabilities, just as poorly designed buildings prevent some from entering. Designers may not realize how simple features built into a web page will assist someone who, for instance, cannot see a computer monitor or use a mouse.

One example of a barrier would be a photograph of a Mayor on a town website with no text identifying it. Because screen readers cannot interpret images unless there is text associated with it, a blind person would have no way of knowing whether the image is an unidentified photo or logo, artwork, a link to another page, or something else. Simply adding a line of simple hidden computer code to label the photograph “Photograph of Mayor Jane Smith” will allow the blind user to make sense of the image.

## Accessible Design Benefits Everyone

When accessible features are built into web pages, websites are more convenient and more available to everyone – including users with disabilities. Web designers can follow techniques developed by private and government organizations to make even complex web pages usable by everyone including people with disabilities. For most websites, implementing accessibility features is not difficult and will seldom change the layout or appearance of web pages. These techniques also make web pages more usable both by people using older computers and by people using the latest technologies (such as personal digital assistants, handheld computers, or web-enabled cellular phones).

With the rapid changes in the Internet and in assistive technologies used by people with disabilities to access computers, private and government organizations have worked to establish flexible guidelines for accessible web pages that permit innovation to continue.

## Resources for Web Developers

To make web pages accessible, the web developer needs to know about web page features that can make a web page less accessible or more accessible. Information about such features is easily available and many software developers are adding tools to web development software to make it easier to make web pages accessible.

Two important resources provide guidance for web developers designing accessible web pages. One is the **Section 508 Standards**, which Federal agencies must follow for their own new web pages. To learn more about the Section 508 Standards:

- The Access Board maintains information on its website at [www.access-board.gov](http://www.access-board.gov) and has a useful guide for web developers at [www.access-board.gov/sec508/guide/1194.22.htm](http://www.access-board.gov/sec508/guide/1194.22.htm);

- The Department of Justice has information about accessible web page design in an April 2000 report to the President. This report is available at [www.usdoj.gov/crt/508/report/content.htm](http://www.usdoj.gov/crt/508/report/content.htm), and
- The General Services Administration hosts an online course for web developers interested in accessible web design. This program was developed in conjunction with

the Access Board, the Department of Justice, and the Department of Education and provides an interactive demonstration of how to build accessible web pages. This course is available at [www.section508.gov](http://www.section508.gov), which also provides information about the Federal government's initiative to make its electronic and information technology accessible to people with disabilities.

## Voluntary Action Plan for Accessible Websites

- **Establish a policy that your web pages will be accessible** and create a process for implementation.
- **Ensure that all new and modified web pages and content are accessible:**
  - Check the HTML<sup>1</sup> of all new web pages. Make sure that accessible elements are used, including alt tags, long descriptions, and captions, as needed.
  - If images are used, including photos, graphics, scanned images, or image maps, make sure to include alt tags and/or long descriptions for each.
  - If you use online forms and tables, make those elements accessible.
  - When posting documents on the website, always provide them in HTML or a text-based format (even if you are also providing them in another format, such as Portable Document Format (PDF)).
- **Develop a plan for making your existing web content more accessible.** Describe your plan on an accessible web page. Encourage input on improvements, including which pages should be given high priority for change. Let citizens know about the standards or guidelines that are being used. Consider making the more popular web pages a priority.
- **Ensure that in-house staff and contractors responsible for web page and content development are properly trained.**
- **Provide a way for visitors to request accessible information or services by posting a telephone number or E-mail address on your home page.** Establish procedures to assure a quick response to users with disabilities who are trying to obtain information or services in this way.
- **Periodically enlist disability groups to test your pages for ease of use;** use this information to increase accessibility.

<sup>1</sup> Web pages are written using a language called HTML (or "hypertext markup language"). HTML is a "markup language" that tells a computer program (called a "browser") how information will appear or will be arranged on a computer screen. HTML tags are specific instructions understood by a web browser or screen reader.

# Examples of Accessible Features for Websites

All images and graphics need to have an alt tag or long description.

Use alt tags for image maps and for graphics associated with the image map so that a person using a screen reader will have access to the links and information.

When navigation links are used, people who use a screen reader must listen to all the links before proceeding. A skip navigation link provides a way to bypass the row of navigation links by jumping to the start of the web page content.

Some photos and images contain content that cannot be described with the limited text of an alt tag. Using a long description tag provides a way to have as much text as necessary to explain the image so it is accessible to a person using a screen reader but not visible on the web page.

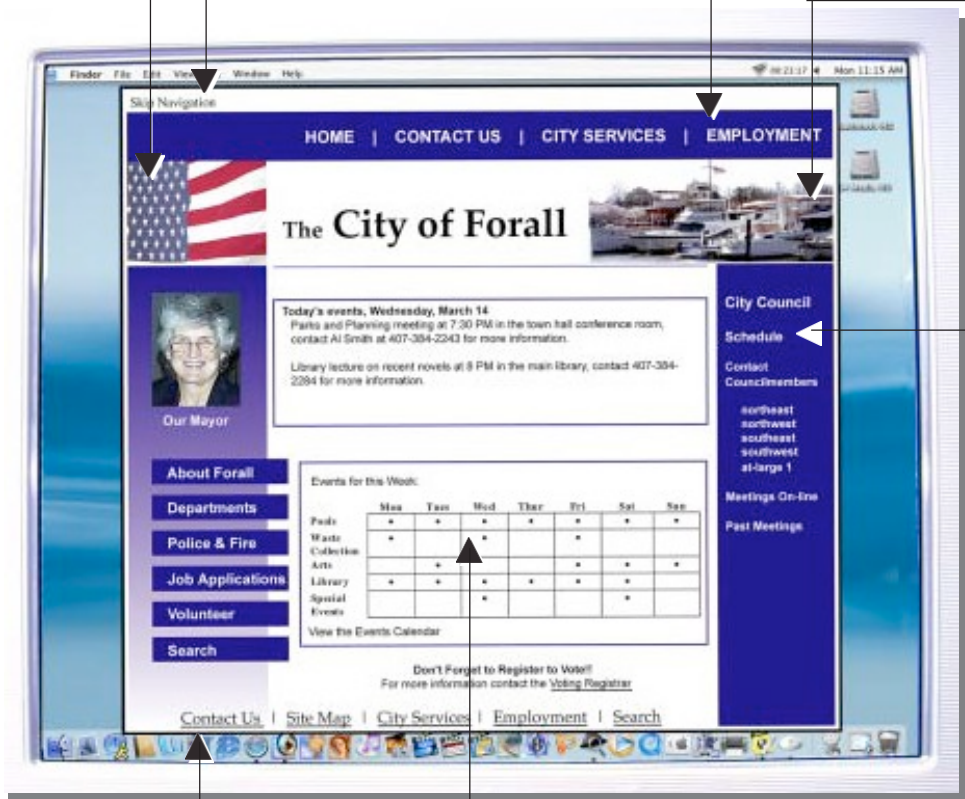

Text links do not require any additional information or description if the text clearly indicates what the link is supposed to do. Links such as "click here" may confuse a user.

When tables with header and row identifiers are used to display information or data, the header and row information should be associated with each data cell by using HTML so a person using a screen reader can understand the information.

A link with contact information provides a way for users to request accessible services or to make suggestions.

## Resources for Web Developers (continued)

A more comprehensive resource is the **Web Content Accessibility Guidelines** developed by the Web Accessibility Initiative. These guidelines help designers make web pages as accessible as possible to the widest range of users, including users with disabilities. The Web Accessibility Initiative is a subgroup of the World Wide Web Consortium — the same organization that standardizes the programming language followed by all web developers.

- Information for web developers interested in making their web pages as accessible as possible, including the current version of the **Web Content Accessibility Guidelines** (and associated checklists), can be found at [www.w3c.org/WAI/Resources](http://www.w3c.org/WAI/Resources), and
- Information about the Web Accessibility Initiative can be found at [www.w3c.org/WAI](http://www.w3c.org/WAI).

## For More Information

### Technical Information Regarding Web Accessibility

For technical assistance regarding Section 508 Standards and how to make web pages accessible to people with disabilities, please contact the Access Board:

**800-872-2253 (voice)**

**800-993-2822 (TTY)**

## Information about the ADA

The Department of Justice provides technical assistance to help State and local governments understand and comply with the ADA. An important source of ADA information is the Department's ADA Home Page on the World Wide Web. This extensive website provides access to ADA regulations; all Department ADA technical assistance materials, including newly-released publications; proposed changes in the ADA regulations; and access to Freedom of Information Act materials, including technical assistance letters. The website also provides links to other Federal agencies with ADA responsibilities.

**ADA Home Page -- [www.ada.gov](http://www.ada.gov)**

In addition, the Department of Justice operates a toll-free ADA Information Line that provides access to ADA specialists during business hours.

### ADA Information Line

**800-514-0301 (voice)**

**800-514-0383 (TTY)**

## Reproduction

Reproduction of this document is encouraged.

June 2003

The Attorney General has determined that publication of this periodical is necessary in the transaction of the public business required by law of the Department of Justice.